



# allegro<sup>2</sup><sup>TM</sup>

owner's manual

Copyright © April 2018 Juniper Systems, Inc. All rights reserved. Information is subject to change without notice.

Juniper Systems® is a registered trademark of Juniper Systems, Inc. Allegro Field PC™ and JSNav™ are recognized trademarks of Juniper Systems, Inc.

ActiveSync, Excel, Hotmail, Internet Explorer, Microsoft, MSN, Outlook, PowerPoint, Visual Studio, Windows, Windows Media, Windows Mobile, Windows Mobile Device Center, Windows Vista, Windows Embedded Handheld, and the Windows logo are trademarks or registered trademarks of Microsoft Corporation in the United States and/or other countries.

The *Bluetooth*® word mark is owned by the Bluetooth SIG, Inc. and any use of such marks by Juniper Systems, Inc. is under license.

Adobe® Acrobat® and Adobe® Reader® are registered trademarks of Adobe Systems Incorporated in the United States and/or other countries.

Google Earth™ mapping service is a trademark of Google, Inc.

The names of other companies and products mentioned herein may be the trademarks of their respective owners.



**WARNING!** This symbol indicates that failure to follow directions could result in serious injury.



**CAUTION:** This symbol indicates that failure to follow directions could result in damage to equipment or loss of information.

Part Number 24533-06



tel: 435.753.1881 | web: [www.junipersys.com](http://www.junipersys.com)  
1132 W. 1700 N. Logan, UT 84321

# Contents

## 1 Getting Started

The Anatomy of the Allegro 2	2
Perform Initial Tasks	3
Home Screen and Windows Start Menu	7
Navigating Around Your Allegro 2	8

## 2 Hardware Components

Keyboard Features	12
Display and Touchscreen	19
Power Management	24
LED Activity Indicators	27
Flashlight	28
SD Cards	28
Connector I/O Module	29
Audio Features	30

## 3 Programs and Settings

Home Screen	32
Windows Start Menu	37
On-Screen Keyboard	37
Suspend, Reset, Power Off, and Restore Defaults	39
Subdued Lighting (Tactical) Mode	41
Compass and Accelerometer	42
Communicating with a Desktop Computer	43
Getting Started Application	44
Information for Software Developers	44

## 4 Bluetooth Wireless Communication

Creating a Partnership	46
Bluetooth Control Panel	47
Serial Device (COM) Control Panel	49

## 5 Wi-Fi Wireless Networking

Connecting to a Wi-Fi Network	52
-------------------------------	----

<b>6</b>	<b>GPS/GNSS</b>	
	Using GPS/GNSS.....	56
	JSNav Application.....	63
<b>7</b>	<b>Camera</b>	
	Camera Settings for Still Images.....	72
	Take Photos and Select Photo Options.....	76
	Videos.....	77
	Photo and Video Library.....	78
<b>8</b>	<b>3G Data Modem</b>	
	GSM Modem.....	80
	Set up the GSM Modem.....	82
	Wireless Safety.....	83
	Maintenance of Your Modem.....	83
<b>9</b>	<b>Barcode Scanner</b>	
	Quick Start – Easily Scan a Barcode Now.....	86
	Barcode Connector Utility.....	88
	Barcode Troubleshooting.....	96
<b>A</b>	<b>Storage, Maintenance and Recycling</b>	
	Storing the Allegro 2 and Battery Pack.....	102
	Protecting the Touchscreen .....	103
	Cleaning the Allegro 2.....	103
	Recycling the Allegro 2 and Batteries.....	104
<b>B</b>	<b>Warranty and Repair Information</b>	
	Limited Product Warranty .....	106
	Extended Warranties.....	108
	Repairing the Allegro 2.....	109
<b>C</b>	<b>Warnings and Regulatory Information</b>	
	Product Warnings.....	112
	Certifications and Standards.....	113
<b>D</b>	<b>Specifications</b>	
	Allegro 2 Rugged Handheld Specifications.....	118

## Index





# 1 Getting Started

# Getting Started

The Allegro 2 Rugged Handheld™ from Juniper Systems features *Bluetooth*, Wi-Fi and an alphanumeric keyboard. Standard accessories include a lithium-ion battery pack, AC wall charger, USB micro client sync cable, hand strap, and a capacitive stylus and tether. A camera, GPS/GNSS, and cellular data modem are options.

## The Anatomy of the Allegro 2 Front and Back Features



- 1 Bumper, Top
- 2 Touchscreen
- 3 Function Keys
- 4 Numeric Keyboard
- 5 LED Indicators
  - red charging indicator
  - green notifications/  
programmable indicator, blue  
programmable indicator
- 6 QWERTY Keyboard
- 7 Microphone
- 8 Power Key
- 9 Attachment Point for Stylus  
Tether and other items (1 of 2)
- 10 Expansion Door
- 11 Camera Lens (option)
- 12 Camera Flash and Flashlight  
Window (option)
- 13 Speaker
- 14 Door to Battery Compartment  
and Card Slots
- 15 Screw Holding Battery Door in  
Place (1 of 4 captive screws)
- 16 Hand Strap Attachment Point (1  
of 2 on the back)

## Battery Compartment and Card Slots

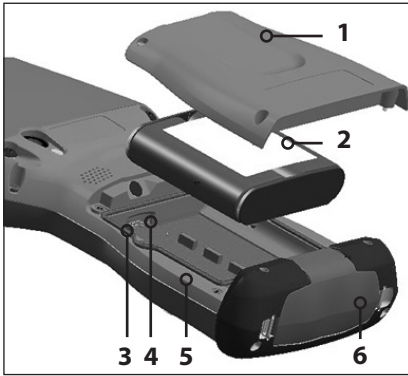

- 1 Battery Door, Screws
- 2 Battery Pack
- 3 Mini SIM Card Slot
- 4 Micro SD/SDHC Card Slot
- 5 Battery Compartment
- 6 Connector Protector

## Connector Module

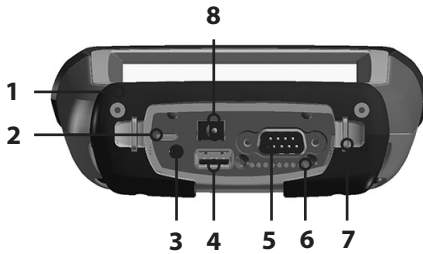

- 1 Connector Module
- 2 USB Client, Micro
- 3 Microphone/Speaker Jack
- 4 USB Host, Full Size
- 5 9-pin Serial Port
- 6 Docking Pin Contacts
- 7 Hand strap Attachment Point
- 8 12-24V DC Jack

## Perform Initial Tasks

When you receive your Allegro 2, perform the tasks outlined in this section before first use.

### Review Documentation

The owner's manual, quick start guide, and Microsoft® License Agreement are available in multiple languages. Other documents like release notes are available in English. These documents are located on our website at: [www.junipersys.com/Juniper-Systems-Rugged-Handheld-Computers/products/Allegro-2#support](http://www.junipersys.com/Juniper-Systems-Rugged-Handheld-Computers/products/Allegro-2#support). View, download, and print documents as desired. (Adobe Reader must be installed on your computer. It is available from Adobe's website at: [www.adobe.com](http://www.adobe.com).)

## Apply a Screen Protector (Optional)

The touchscreen is extremely scratch-resistant, so a screen protector is not included with the Allegro 2. If you decide to apply one, refer to the installation instructions included with the screen protector for specific details.

## Install the Battery Pack, SD Card, and Mini SIM Card

The Allegro 2 uses a rechargeable Li-Ion battery pack. Install and charge the battery pack as follows:

**!** **CAUTION:** Always power off the handheld before removing the battery. Failure to do so may cause loss of data or damage to the handheld.

1. The battery compartment is accessed from the back of the handheld. Loosen the four captive screws holding the battery compartment door in place using a #1 Phillips screwdriver. Remove the door.

**!** **CAUTION:** The Allegro 2 is not sealed against water and dust when the battery door is not installed.



2. If you are using a micro SD card for additional memory or a mini SIM card with the 3G Data Modem (optional), you can install them now before you install the battery pack, or at another time. See more details about these cards in Chapter 2, Hardware Components, Micro SD Cards and Chapter 8, 3G Data Modem, Install the Mini SIM Card.



3. Place the Li-Ion battery pack in the compartment. Make sure the + and - symbols on the battery pack label align with the symbols inside the compartment.



Line up the symbols on the case and the battery pack as shown

4. Replace the door and tighten the screws.
5. Plug the AC wall power charger that came with the Allegro 2 into a wall socket. Plug the other end into the DC power jack on the Allegro 2. The red LED on the keyboard blinks when the battery pack is charging.

### Attach the Hand Strap and Stylus Tether

A hand strap, capacitive stylus and tether are included with the handheld.

*Note: A stylus is not required to use the touchscreen. The optimal way to make selections is by finger touch.*

If the hand strap was not attached at the factory or you want to move it to the other side, follow the diagram below to attach it to the right or left side of the handheld:

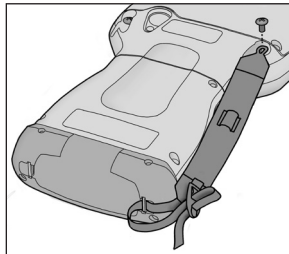

One end of the stylus tether is attached to the stylus. To attach the tether to the handheld, follow these steps:

1. Push the free tether loop through one of the tether attachment points on the back of the handheld towards the top.



2. Insert the stylus with the attached tether through this loop and tighten the loop.
3. Place the stylus into the holder on the hand strap.

### Perform Set Up

1. Press the power key . The handheld powers on and begins the startup process. A splash screen is shown that includes a progress indicator at the bottom.
2. A Microsoft® Windows Embedded Handheld screen is shown.
3. The Update Time screen appears. Adjust the time zone, date and time if necessary and tap OK.

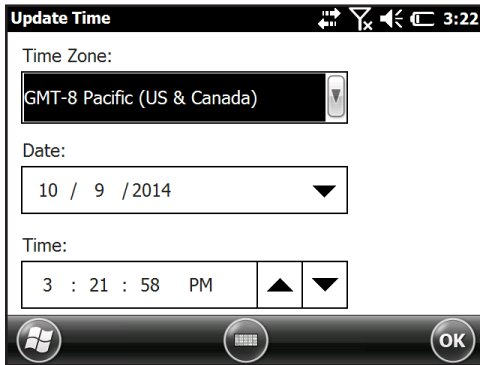

4. You might be asked to restart the handheld to complete installation.
5. The Home screen appears (the layout varies by model).

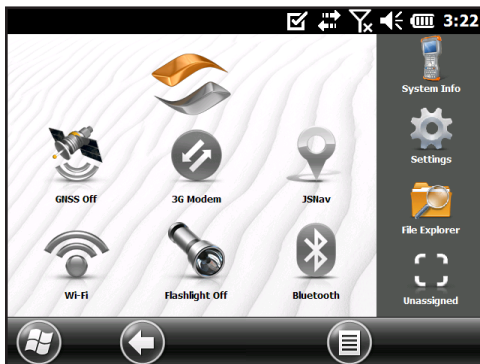





6. Press the power key  to suspend the handheld. Charge the battery pack at room temperature (68° F. or 20° C.) for four to five hours. While the battery pack is charging, the red LED blinks. When it is fully charged, the red LED is solid.

## Install the Operating System in Other Languages

The operating system is provided in English by default. It is also available in other languages. You can download the operating system in one of these languages from our website. Go to [www.junipersys.com/Juniper-Systems-Rugged-Handheld-Computers/support/Downloads/Allegro-models/Allegro-2](http://www.junipersys.com/Juniper-Systems-Rugged-Handheld-Computers/support/Downloads/Allegro-models/Allegro-2). Full installation instructions are also available here.

## Home Screen and Windows Start Menu

You need to be familiar with two screens as you read this manual and use the Allegro 2: the Home screen and Windows Start menu.

*Note: The orange  then home  key sequence toggles back and forth between the Home screen and Windows Start menu. The home  key takes you to the Home screen. The Windows soft key  toggles between the Windows Start menu and the last screen shown.*

## Home Screen

The Home screen is the main control center for the Allegro 2. The content varies based on which model you have and can be customized.





This screen is automatically shown when the Allegro 2 is turned on. You can get to it from any other screen by pressing and releasing the Home screen  key on the keyboard.

## Windows Start Menu

The Windows Start menu gives you access to all of the applications on the Allegro 2.



You can get to it from any screen by tapping the Windows tile  (soft key) on the display or pressing the  + Home  keys on the keyboard.

## Navigating Around Your Allegro 2

### Using Gestures and Making Selections

The Windows® Embedded Handheld operating system enhances the ability of the handheld to recognize touch gestures, making it easy to use a finger to navigate. Use of the capacitive stylus is an option. The keyboard keys can also be used.

Navigation options vary depending on the screen you are viewing. Here is a partial list of options:

#### *Vertical and Horizontal Movement*

- Flick up, down, or sideways on the touchscreen.
- For more precise positioning, touch, hold, and move the screen up or down.
- Use the scroll bar if it is available.

- Use the navpad to move around on a screen.
- A horizontal scrolling menu is located on control panel screens near the top.

Up/Down Con... < Program Buttons > Up/Down Con...

## Make a Selection





### Using the Touchscreen

- Press or tap the function gadget or application icon you want to select, turn on, activate, or turn off.
- Press and hold a function gadget to bring up a control panel, menu, or list.

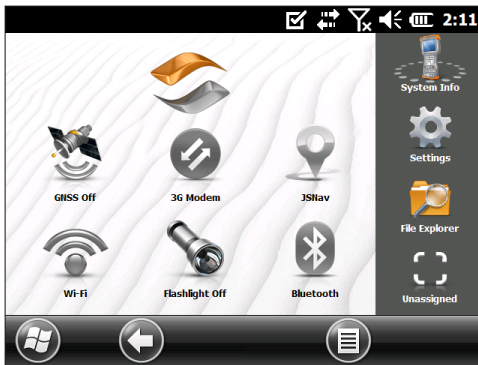
### Using the Keyboard

- Use the up  down  right  and left  arrow keys on the navpad to select (highlight) a gadget or icon on the screen. A ring appears around the selection. System Info has been selected below:



- Perform the selected action by pressing the return key  or the center action key . For dashboard gadgets like Wi-Fi, one press of the return key  shows you which icon is selected, a second key press performs the action, and a third key press turns the action off. For application icons on the Start screen or in favorites, continue to use the arrow keys on the navpad and return  or action keys  until you get to the screen or menu you want.



## Updates to the Operating System and Documents

Updates to the operating system and technical documents are located on our website at [www.junipersys.com/Juniper-Systems-Rugged-Handheld-Computers/products/Allegro-2#support](http://www.junipersys.com/Juniper-Systems-Rugged-Handheld-Computers/products/Allegro-2#support). Compare part numbers to see if you have the most recent version of the Owners Manual and Quick Start Guide.

### ***View System Information for Your Allegro 2***

To view your operating system version number, press the System Info icon  on the Home screen or go to *Start > Settings > System > System Information*. Expand *System ID*. Compare version numbers here and on our website to see if your OS is current. Full installation instructions to update the operating systems are also available at this website location.

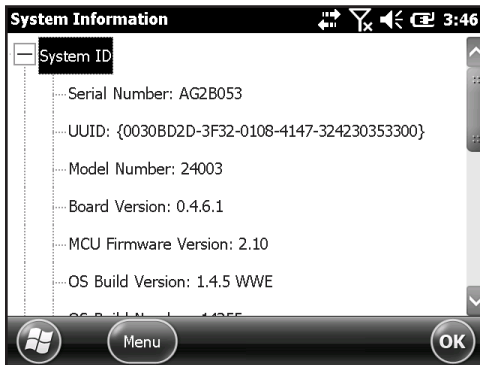



## 2 Hardware Components

















# Hardware Components













This chapter discusses the Allegro 2 Rugged Handheld hardware features and usage.

## Keyboard Features













The Allegro 2 has a numeric keyboard, function keys, and a QWERTY keyboard. The keys are sealed and have backlight illumination. Some keys and LEDs are programmable.





Key	Press and Release	Shift  + Key Press	Blue  + Key Press	Orange  + Key Press
 F1	F1		F7	Show orange key menu in browser
 F2	F2		F8	
 F3	F3		F9	
 F4	F4		F10	Toggle backlight off and on
 F5	F5		F11	Turn backlight down in increments
 F6	F6		F12	Turn backlight up in increments
 7	7	&		
 8	8	*		
 9	9	(		
 ESC	Escape		Task Manager	
 4	4	\$		
 5	5	%		
 6	6	^		
	Back-space (Delete)		Enable or disable touchscreen	

Key	Press and Release	Shift ⇧+ Key Press	Blue  + Key Press	Orange  + Key Press
	Enter (return)		Select OK or X on the screen	
<b>1</b>	1	!		
<b>2</b>	2	@		
<b>3</b>	3	#		
<b>0</b>	0	)		
	Move left cursor		Home	Volume down
	Move right cursor		End	Volume up
	Move up cursor		Page up	Brightness up
	Move down cursor		Page down	Brightness down
	Action			
	Home screen			Start screen
	Blue command (sticky on second press)			
<b>ALT</b>	ALT command			
	Left tab (back)			Keyboard brightness down
	Right tab (forward)			Keyboard brightness up



Key	Press and Release	Shift ⇧+ Key Press	Blue Ⓔ + Key Press	Orange Ⓜ + Key Press
	Control command (sticky on second press)			
	Orange command (sticky on second press)			
	w	W	@	Wi-Fi Control Panel
	t	T	%	Task Manager
	p	P	)	Power Control Panel
	a	A	~	Record audio note
	s	S		Sensors Control Panel
	f	F	[	Flashlight toggle
	g	G	]	GNSS Control Panel
	c	C	;	Launch camera
	b	B	'	Bluetooth Control Panel
	n	N	<	Notes

Key	Press and Release	Shift ⇧ + Key Press	Blue Ⓚ + Key Press	Orange Ⓚ + Key Press
	m	M	>	Modem Control Panel
	Shift command <ul style="list-style-type: none"> <li>▪ Shift, one key press</li> <li>▪ CAPS lock, two key presses</li> <li>▪ Release CAPS lock, three key presses</li> </ul>			
	Power <ul style="list-style-type: none"> <li>▪ Suspend or resume, one key press</li> <li>▪ Open Power Menu, press and hold</li> </ul>			

## Orange Power Key Menu

To view the orange power key menu on your browser, press the orange  + **F1** keys.







**Orange Power User Keys**

Press the Orange Key  + character below to send a command

Press the Orange Key twice to lock the Orange Key On



Press a third time to unlock the Orange Key



**Control Panels**

-  + Home = Windows Start Menu
-  + A = Record Audio Note
-  + B = Bluetooth Control Panel
-  + C = Camera
-  + F = Flashlight Toggle
-  + G = GNSS Control Panel



## Programmable Keys

The **F1** through **F6** function keys, home  key, and action  key can be set up programmatically. These keys can also be selected to launch applications or functions from the Buttons menu as follows:

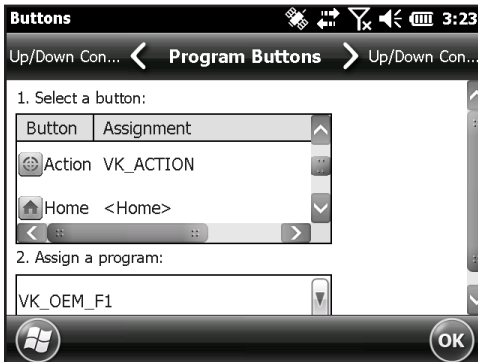

1. To bring up the Program Buttons menu, select the Settings icon on the Home screen, and then *Personal* > *Buttons*. Or, go to the Start screen by selecting the Windows  soft key or pressing the shift  + home  keys, then selecting *Settings* > *Personal* > *Buttons*. Under 1. *Select a button*, a list of programmable keys and their current assignments is shown.

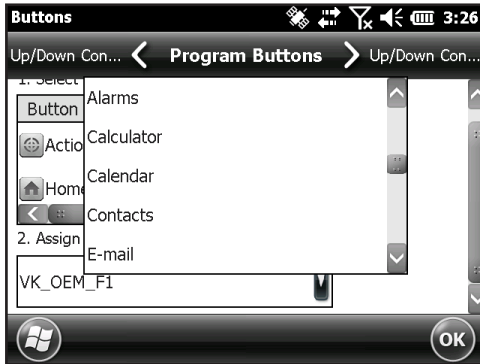

2. Select the key you want to reassign.
3. At the bottom of the screen under 2. *Assign a program*, select the down arrow key to display a list of programs and functions. Select the item you want to reassign to the selected key.



## Keyboard Backlight

Make keyboard brightness adjustments by pressing the orange  + forward tab  or back tab  keys to increase or decrease the keyboard brightness. You can also use the Backlight control panel located at *Start > Settings > System > Backlight*. Select the External Power screen or Battery Power screen from the horizontal menu near the top of the screen.

Move the *Keyboard* slider up to brighten the backlight or down to dim it. Dimming the keyboard backlight saves battery power when the Allegro 2 is in use.

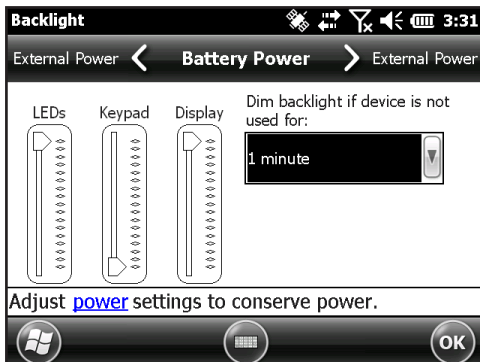

*Note: The keyboard backlight turns off when the display backlight dims or the Allegro 2 is suspended.*

## Display and Touchscreen

The Allegro 2 has a bright color display and capacitive touchscreen with a diagonal viewing area of 4.2 inches (107 mm). It is easy to view outdoors and is sealed against water and dust. The Windows® Embedded Handheld operating system enhances the ability of the Allegro 2 to recognize touch gestures, making it easy to use a finger to make selections and navigate. You can also use a capacitive stylus.

### Display and Touchscreen Settings

#### *Type and Orientation*

To adjust the display settings, including the text size and orientation, go to the Screen control panel by pressing *Start* > *Settings* > *System* > *Screen*.

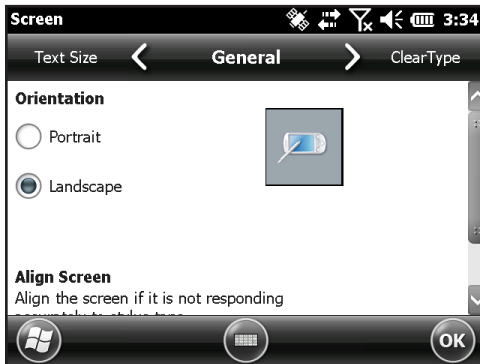

The screen is designed to be used in landscape orientation.

*Note: Capacitive touchscreens do not need to be aligned.*

### Touchscreen Modes

The touchscreen is optimally designed for finger use. The default touchscreen mode can be adjusted to best match your application and environment, especially if you are using a capacitive stylus.



To adjust the touchscreen profile, go to the Touch control panel by pressing *Start > Settings > System > Touch*. Modes for finger or stylus use are shown.

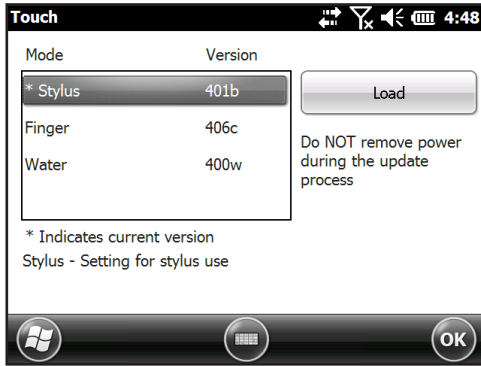

Select the preferred mode, and tap *Load*. Do not interrupt the loading process. You can try different modes to see which one works best for you.

### ***Zooming in on the Display***

Zooming in on the display increases the view by 50 percent and makes selecting content much easier.

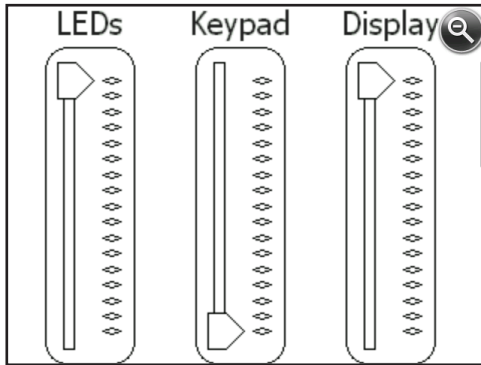

Zoom options:

- **Hold-to-Zoom** - The Hold-To-Zoom feature allows a quick method to zoom into a small feature on the screen.  
*Note: A key is not set to launch this feature by default. To use this feature, go to the Buttons control panel, Program*

Buttons screen to assign a key to launch the function. Select the Windows  soft key or press the shift  + home  keys, then *Settings > Personal > Buttons*.

Press and hold the assigned key and tap on the screen in the area on which you want to zoom. The screen focuses on that location. Make selections as desired. Release the key to return to the regular screen size.







- Magnifying glass - Tap on the title bar at the top of the screen to display the pop-up icons. Select the magnifying glass on the left.



This zooms in on the content. Move the screen around with your finger until you find the information you want. Select the magnifying glass symbol in the upper right corner of the screen to return the view to the regular size.

### ***Display Backlight Settings***

The display backlight can be toggled off and on by pressing the  + **F4** keys.

The default setting for the brightness of the display backlight is 80%. Adjust the display brightness by pressing a brightness down key sequence:  + Up Arrow  or  + **F6**, and brightness up key sequence:  + Down Arrow  or  + **F5**. You can also make brightness adjustments through the Backlight control panel by pressing *Start > Settings > System > Backlight*. External Power and Battery Power are adjusted on different screens. Select these screens from the horizontal scrolling menu near the top of the screen.

Move the *Display* slider up to brighten the backlight or down to dim it.

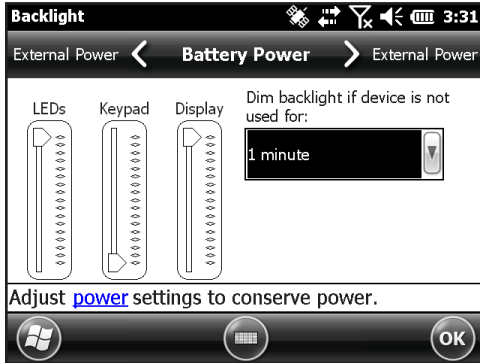

### *Dimming the Display Automatically*

The display has a minimum brightness setting that it dims to when the Allegro 2 is idle for the time interval indicated. The display backlight dims by 50% or more, so the display is still partially visible. You can adjust the dim time interval (see the previous Battery Power screen) for battery and/or external power. Dimming the display backlight saves battery power.

To bring the backlight back up to the full brightness setting, tap on the dimmed display.

*Note: The Allegro 2 can be set up in subdued lighting (tactical) mode. Refer to Chapter 3 for instructions.*

### *Turning the Screen Off Automatically*

You can set up the display backlight to turn off after set intervals. Tap on the top title bar from any screen, and select the battery icon from the list of applications that appears.



Alternately, go to the Backlight control panel. Press *Start* > *Settings* > *System* > *Backlight*. Near the bottom of the screen it says “Adjust Power Settings to conserve power.” Select the hyperlink power (see the previous Battery Power screen).



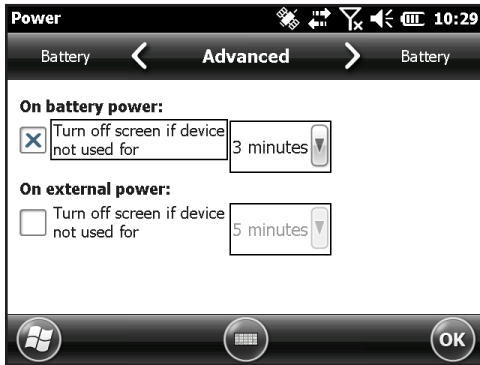

The Power control panel appears. Select *Advanced* from the horizontal scrolling menu near the top of the screen. For battery and external power, select how long the screen stays on when it is not in use. Shorter times save battery power.



## Disabling and Enabling the Touchscreen

You can disable the touchscreen. This is useful when you are running an application and you want to see the screen while avoiding accidental touchscreen activation. You can move around and make selections using the keyboard. The touchscreen can also be disabled for cleaning purposes.

When the touchscreen is disabled, this icon  is shown in the title bar until the touchscreen is enabled again.

- Press the  + backspace  keys to toggle the touchscreen on and off.
- Press and hold the power key  to display the Power Key menu. Select *Disable TS*. To enable the touchscreen using this menu, use the down arrow key  to highlight *Enable TS*, and press enter .

## Power Management

The Allegro 2 uses a Li-Ion rechargeable battery pack.

**!** **CAUTION:** Only use batteries designed for the Allegro 2 from an approved vendor. Use of non-approved batteries may void your product warranty.

### Charging the Battery Pack

To charge the battery pack, suspend the handheld, then refer to the instructions in *Chapter 1, Getting Started*. It typically takes four to five hours to fully charge a battery pack.

We recommend that you keep the handheld battery pack charging when it is not in use for up to two weeks. When you plug the handheld into the wall charger that comes with it, the batteries are prevented from being overcharged.

The Li-Ion battery pack is charged most efficiently at room temperature (68°F or 20°C). The battery pack will not charge if it is too hot or too cold.

**!** **CAUTION:** The Allegro 2 is not sealed against water and dust when the battery door is not installed properly.

### Battery Life

Battery life on a full charge can be 20 hours or more. This varies depending on the applications used, backlight usage, and radio usage.

To see the remaining battery power, tap on the top title bar from any screen and select the battery icon from the list of applications that drops down.



The Power control panel appears, displaying the remaining battery power.

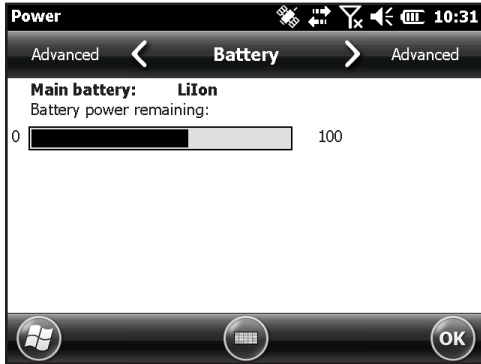

Battery packs last approximately 1,000 to 3,000 charging cycles before they need to be replaced. This is impacted by applications and environmental factors.

Depending on the current charge on the battery, you may see different displays when turning on the unit. If the battery is completely discharged, you will see the following image.

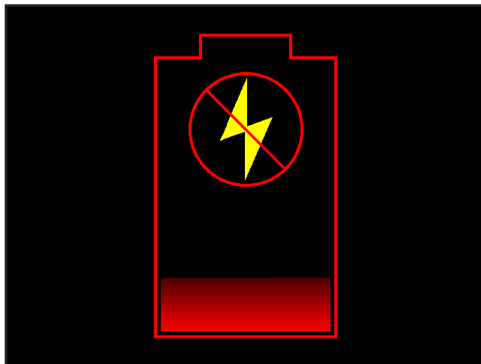

If the battery has some charge, but not enough to boot the unit, you will see this image.

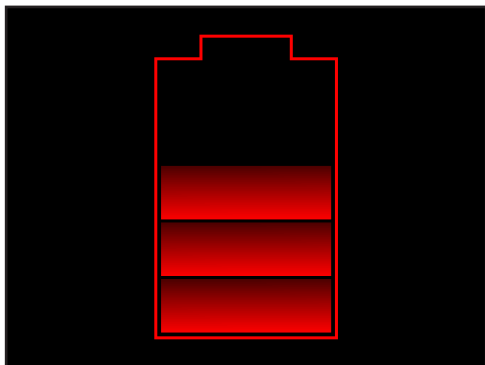

In either case, you will need to connect the unit to external power to charge the battery. This display will continue until the unit has enough of a charge to finish the boot process. Depending on the charge of the battery, this can take up to four hours.

The Allegro 2 is designed to run in either of two power states, battery power, or external power with battery installed. The unit is not designed to run on external power without a battery. Doing so can damage internal components of your unit and void the warranty.

### **Summary of Options to Reduce Power Usage**

You can adjust some settings to preserve power:

- Turn off the display (suspend) after a set interval. See *Display Backlight Suspend Interval* earlier in this chapter.
- Dim the backlight after a set interval. See *Adjusting the Keyboard Backlight* and *Adjusting the Display Backlight* earlier in this chapter.
- Disable radios when not in use. Turn radios off from the Home screen or press *Start > Settings > Connections > Wireless Manager*.

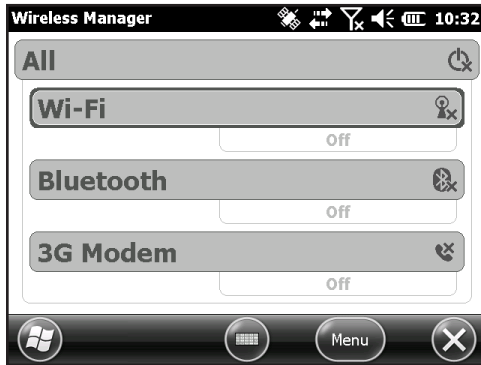

## LED Activity Indicators

LED activity indicators are located on the keyboard on the left side next to the **·** key.



- Red LED on the bottom (associated with power adapter):  
Blinking - AC adapter is plugged in, and the battery is charging  
Solid - AC adapter is plugged in, and the battery is full (not charging)
- Green LED on the top (associated with notifications):  
When the operating system has something to notify you of, this LED behaves accordingly. For example, if you turn on GPS/GNSS the green LED blinks periodically. You can set up some notification features. Go to *Start > Settings > Sounds & Notifications > Notifications* tab. Under *Event*: select *Reminders*. Scroll down to set up other notification features as desired, including *Play sound* (plus repeat and choice of sound), *Display message on screen*, and *Flash light for* (plus the desired minutes).
- Blue LED in the same location as the green LED (the blue and green LEDs can not be shown simultaneously): The Blue LED is not tied to a key or a notification by default.





The green and blue LEDs can be programmed through the JS Application Programming Interface (JSAP) located on our website at [www.junipersys.com/Juniper-Systems-Rugged-Handheld-Computers/support/Developers/Allegro-models](http://www.junipersys.com/Juniper-Systems-Rugged-Handheld-Computers/support/Developers/Allegro-models).

## Flashlight

Geo units have a flash LED located underneath the camera window on the back of the Allegro 2. It can be used as a flashlight, although its primary purpose is as a flash for the camera.



To use the flashlight you can tap the flashlight gadget  if it is on the Home screen or press the orange  + **F** keys. Tap on the icon or press the keys once to turn on the brightest illumination, again for medium brightness, and a third time to turn it off.

## SD Cards

The Allegro 2 has a slot for a micro SD card located in the battery compartment. To insert or remove a card, follow these steps:

 **CAUTION:** Always power off the handheld before removing the battery. Failure to do so may cause loss of data or damage to the handheld.

1. Power off the handheld by holding the power button until the Power Button menu appears and selecting Power Off. Ensure that your unit is not plugged in to external power.
2. Loosen the screws to the battery compartment, and remove the door. The hand strap remains attached.

 **CAUTION:** The Allegro 2 is not sealed against water and dust when the battery door is not installed properly.

3. Remove the battery pack.
4. An image on the battery compartment label shows the correct location and orientation for the SD card (slot on the right). Push the card into the slot to insert it. To remove the SD card, pull it out.



5. Replace the battery pack, and attach the battery door.
6. Power up the handheld.

## Connector I/O Module

The Allegro 2 connector I/O module has the following jacks and connectors:

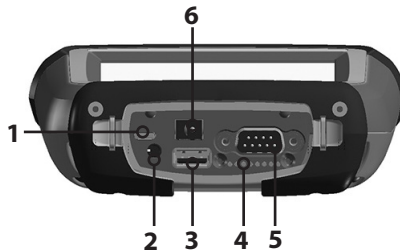

1. USB client, micro B
2. Audio jack: 3.5mm; supports speaker, microphone or stereo output (pin detect)
3. USB host, full size A
4. Docking pin contacts
5. COM1: RS-232C 9-pin D-sub connector, 5 V @500 mA available on pin 9 (ring in) under program control
6. Power input jack: 12 to 24 VDC for power input and battery charging

The connector I/O module is user-replaceable. Contact our sales department or your supplier for details.

*Note: The connectors are sealed and do not require a connector protector to prevent water ingress.*

## Audio Features

The Allegro 2 has the following audio features:

- Speaker - The speaker sound is loud and clear. Listen to audio notes, video sound, and music files.
- Microphone - Use the microphone to record audio notes or add sound to a video when using the camera (option).
- Audio Jack - The audio jack supports a stereo headset or headset/microphone combination with 3.5mm connections.

## Adjusting Audio Settings

To set audio options, tap on the top title bar and select the audio icon from the list of applications that drops down. Or, press *Start > Settings > System > Audio*.



The Audio control panel, *Output* screen, is shown:



From the *Output* screen, you can adjust the speaker options. Select the *Input* screen from the horizontal menu near the top of the screen. You can adjust the onboard and headset microphones as desired.



# 3 Programs and Settings





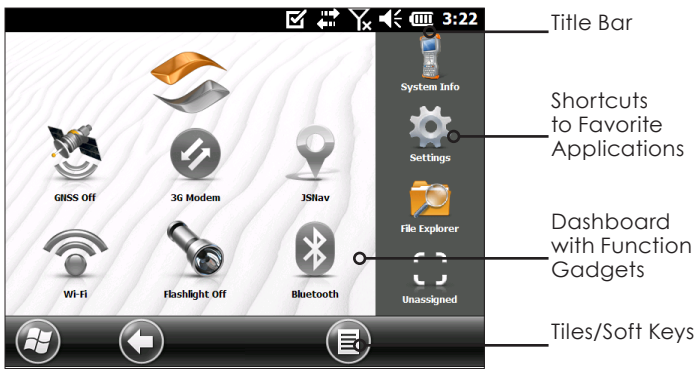

# Programs and Settings

This chapter discusses the Allegro 2 Rugged Handheld programs and settings.

## Home Screen

The Home screen is your main control center for the Allegro 2. View vital system information and quickly access functions and applications that are frequently used. The default home screen for a basic unit is shown below. Different functions are shown depending on which model you have. You can customize the Home screen.



You can get to the Home screen from any screen by pressing the Home  key on the keyboard. Tap on a gadget or icon to turn a function or application on or off. Tap and hold a gadget to go to a control panel. From the keyboard you can use the up  down  right  and left  arrow keys to select (highlight) a gadget or an icon on the screen. Perform the selected action by pressing the return  key.

## Title Bar and Pop-Up Icons

The title bar is at the top of every screen. It identifies the page and shows status icons indicating functions like connectivity status, audio, power, and time. Tap the title bar to bring up larger, touchable icons in a horizontal-scrolling bar. Select an icon to use or to view the settings and adjust them as desired.



## Dashboard





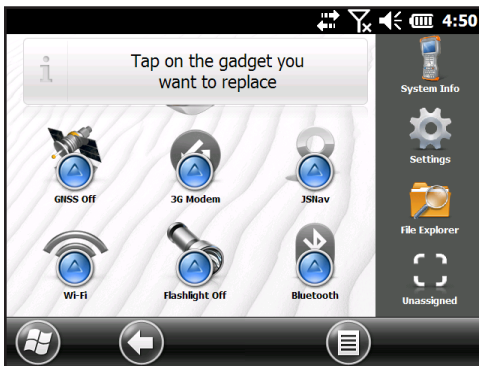



The dashboard consists of a background image and up to six dashboard gadgets that serve as functional indicators and control keys.

You can switch between two color schemes and select which gadgets are shown. Tap on the menu  soft key and select *Switch Color Scheme* to change color schemes or *Configure* to select gadgets. The current gadgets are covered with a blue symbol as shown below.







Tap on the gadget you want to replace. A list of available dashboard gadgets is shown. Tap on your new selection. The dashboard icon changes when you make a selection. If "None" is selected, the space becomes blank.

## Dashboard Gadget Functions

	Wi-Fi: Shows the state of the Wi-Fi radio and provides the name of the wireless network to which it is attached.
	Bluetooth® wireless technology: Shows the state of the Bluetooth radio.
	Email: Shows the number of unread email messages. If there are multiple email accounts, the total number of unread messages is aggregated from all accounts.
	Calendar: Shows the next appointment.
	Tasks: Shows the current number of tasks.
	GPS/GNSS Status (Geo model): Shows the current state of GPS/GNSS reception and the state of the GPS/GNSS receiver. It also shows the number of satellites in view, the number of satellites used to calculate the fix (SV), the type of fix (2D, 3D, etc.), and the quality of the fix (PDOP).
	JSNav (Geo model): An application that lets you easily collect waypoint or track data and navigate back to any saved waypoint or track.
	3G Data Modem (Geo model with cell modem): Shows the on/off state of the optional cellular modem.
	Flashlight: Shows the on/dim/off state of flashlight feature (included with camera).

### Gadget Color Indicators

Wi-Fi, Bluetooth, GPS and 3G data modem gadgets indicate status using these colors:



	Gray: Off or inactive
	Yellow: Partial state (getting satellite fix, etc.)
	Green: Active and available
	Blue: Notification state (on or connected)

	Red: Error state, powering up or down, no GPS/GNSS fix, or unavailable (3G data modem is red when power is changing from on/off. Wi-Fi is red when an access point is available but not connected.)
---	---

### Favorites Bar

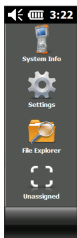
The favorites bar consists of shortcuts to specific applications. It is located below the dashboard when the screen is in portrait mode and to the side of the dashboard when it is in landscape mode. Tap on a shortcut icon to launch an application.



You can use it to jump between the applications you use most. While running an application, press the Home key  and select a different application from your favorites. To return to the first application, press the home key  again, then tap on the first application you were running.

You can customize which application shortcuts are shown. Tap and hold on the shortcut you want to change to bring up a list of available applications.

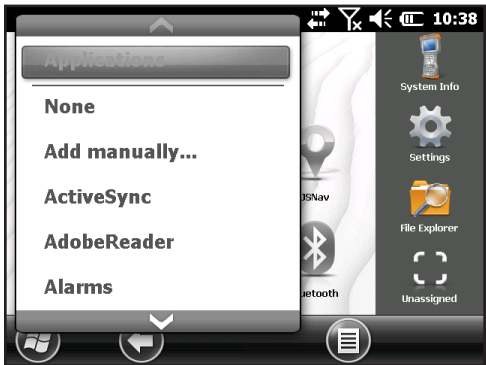



Tap on your selection. The icon on the home screen changes to the icon associated with the new application.

### Tile Bar









Touchable tiles (or soft keys) are shown in the tile bar at the bottom of each screen. Up to five tiles are shown, depending on which screen you are on.

For example, the Home screen tile bar (shown below) consists of: 1) the Microsoft® start tile that takes you to the Start menu, 2) the back tile that takes you to the last application running, and 3) the menu tile that lists options for customizing the dashboard. The third and fifth tile positions are empty.



Tap on a tile to perform the actions associated with it.









Tile examples:

	Start		Lock
	Minimize		Edit
	Navigate back		Delete
	Menu		On-screen keyboard

## Windows Start Menu

The Windows Start menu gives you access to all of the applications on the Allegro 2.



You can get to the Start menu from any screen by tapping the Windows tile  (soft key) on the display or pressing the  + Home  keys on the keyboard. On the touchscreen, tap the application icon you want to select. From the keyboard you can use the up , down , right  and left  arrow keys to select (highlight) an icon on the screen. (Home is selected on the previous screen.) Perform the selected action by pressing the return  key.

## On-Screen Keyboard

To activate the on-screen keyboard, select the keyboard tile  located at the bottom of active applications like Tasks that use keyboard input.

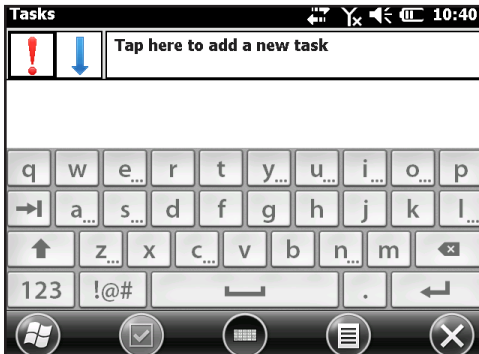

The default keyboard is Mega Keys, featuring large keys and increased functionality.

To view and select other options including *Block Recognizer*, *Letter Recognizer*, and *Mega Keys Night*, press and hold the keyboard tile . To turn the on-screen keyboard off, press the keyboard tile.

### **Mega Keys (and Mega Keys Night) Keyboard Features**

- Pressing on a character with a finger or stylus highlights it. Releasing the key prints the character on the screen.
- If you accidentally press the wrong character and have not released the key yet, you can slide to the correct character before releasing the key.
- There are four main keyboard screens: lowercase, uppercase, numeric, and symbols. To navigate to different screens, press the modifier keys in the lower left corner of each screen as shown in the following graphic for the lowercase keyboard. Press the up arrow to go to the uppercase keyboard, the number key to go to the numeric keyboard, and the symbol key to go to the symbols keyboard.



- Tap on the shift key for a single uppercase letter. Tap on the shift key twice to lock the uppercase key. Tap once more to return to the lowercase keyboard.
- To enter a character from another screen (such as a number or symbol), press and hold on the modifier key, slide to the character you want, then release the key. The character is printed, and you are returned to the screen you started from.
- Some keys have an extra character bar that includes items like accented characters or additional symbols. These keys have three dots in the bottom right corner like the z key . Press and hold the key to bring up the extra bar. Tap the desired item or dismiss the bar by tapping outside of the bar.

- A calculator is available from the numeric screen. Press the Calc key to launch the calculator application.
- The backspace and the space keys can be repeated by pressing and holding those keys.

## Suspend, Reset, Power Off, and Restore Defaults

Use the power key  to suspend, reset, power off, or restore the Allegro 2 to its factory state. To access the Power Key menu, press and hold the power key.



### Suspending and Resuming the Allegro 2

We recommend you suspend your handheld when it is not in use for a day or two.

Suspending the handheld is different from powering it off. When the device is suspended it goes into a low power mode. Some battery power is used during suspend.

1. Press and release the power key  or select the *Suspend* option on the Power Key menu. The backlight shuts off. It can take several seconds to fully suspend. When the cell modem is on, it can take up to 45 seconds.
2. The green LED turns on during the suspend process and goes off once it is completely suspended to let you know it has finished suspending.
3. To resume the device from suspend mode, press and release the power key again. When it is resumed, the handheld resumes where it was before it was suspended.

## Resetting the Allegro 2

If the Allegro 2 is unresponsive, slow, or programs won't launch, performing a reset might solve the issue. You may be asked to perform a reset when an application is installed.

**!** **CAUTION:** Be aware that during a reset, applications are closed and unsaved work may be lost.

Follow these steps to reset your Allegro 2:

1. Save open files, and close any running programs.
2. Press and hold the power key  until the Power Key menu appears.
3. Tap *Reset*.

You can also reset the handheld by pressing the power key for 10 seconds or until the screen goes dark. After a few seconds, the handheld automatically turns on. This method is useful if your Allegro 2 locks up.

## Powering Off and On the Allegro 2

To preserve battery power, we recommend you power off the Allegro 2 if it will not be used over a long weekend or several days. Remember that when a unit is suspended it is still operating, though at a very low power state, and this consumes battery power.

**!** **CAUTION:** Be aware that when the Allegro 2 is powered off, it closes all programs and powers down all system components except for the real-time clock. Unlike suspend mode, the device resets when it is powered on again. Any unsaved data is lost.

1. Save open files, and close any running programs.
2. If you are using external power, unplug it.
3. Press and hold the power key  until the Power Key menu appears.
4. Tap *Power Off*. A warning dialog appears. Tap OK.



To power on your handheld, press the power key.

*Note: If an Allegro 2 is stored for an extended period of time, the battery should be removed.*

## Restoring the Allegro 2 to its Factory State (Clean Boot)

Follow the steps below to restore user storage, settings, and icons on your Allegro 2 to their original factory defaults.



**!** **CAUTION:** Restoring the Allegro 2 to its original factory state permanently erases data saved on the handheld, any software you installed, and any changes you made to the handheld, including changes to settings.

1. Back up files and programs you want to keep onto another computer.
2. Save open files and close running programs on the handheld. Press and hold the power key  until the Power Key menu appears. Tap *Reset*.
3. When the screen turns black, press and hold the power key  again until the bios screen is shown.
4. Move the top slider on the screen to the right to set or clear factory defaults (this clean boots the handheld).
5. Tap *Exit*. The boot process continues. The Update Time screen is shown. Update the information as needed and press *OK*.

## Subdued Lighting (Tactical) Mode

In some environments subdued lighting is preferred. The display backlight, LEDs, and keyboard illumination can be subdued during the startup process and normal operation.



### Set Up During a Reset

1. Save open files and close running programs on the Allegro 2. Press and hold the power key  until the Power Key menu appears. Tap *Reset*.
2. When the screen turns black, press and hold the power key  again. The bios screen is shown.
3. Move the slider on the screen to the right to turn the tactical mode on.
4. Tap *Exit*. The boot process continues.

To restore the handheld to default lighting, follow the same steps outlined above.

## Adjust Brightness Using the Keyboard

You can adjust the display and keyboard brightness any time from the keyboard.

For the display, brightness up is  + **F5** and brightness down is  + **F6**.

For the keyboard, brightness up is  + forward tab **→** and brightness down is  + back tab **←**.

## Adjust the Backlight Control Panel

You can also subdue the keyboard and display brightness through the Backlight control panel. Press *Start* > *Settings* > *System* > *Backlight* and then *External Power* or *Battery Power* from the horizontal scrolling menu near the top of the screen. Adjust the sliders as needed for both power sources. Changes affect all operations.

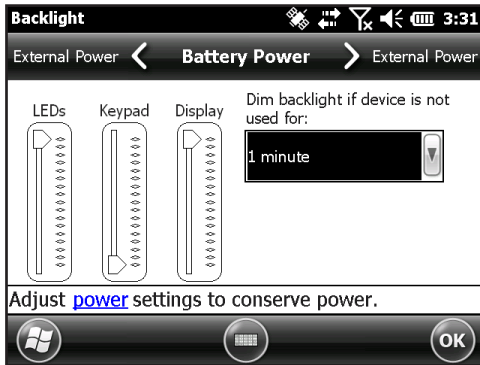

## Compass and Accelerometer

The Allegro 2 has a built-in compass and accelerometer. The compass is used for embossing GPS information on pictures taken with the camera, or embedding GPS information into jpg files. The compass is also used by the JSNav program. The accelerometer assists the compass in determining direction, even when the device is not resting flat. (See *Chapter 6, GPS/GNSS, JSNav Application* and *Chapter 7, Camera, Geotagging*.)

The compass and accelerometer can also be used by other user applications.

## Sensors Control Panel

The Sensors control panel lets you see the compass and accelerometer working, set the magnetic declination angle, and calibrate the sensors. Select *Start > Settings > System > Sensors*.



- The *Magnetic Declination* angle is the difference between True North and magnetic North. Applications that are using True North use this value to adjust the readings from the compass.
- To calibrate the compass, select *Calibrate Compass*. Rotate the handheld around all three axis several times in every orientation possible (for at least 10 seconds). Press *Stop* when you are done. Calibrating the compass is very important and needs to be done often. Changes in environment, added attachments to the handheld, and mounting options can affect the sensor readings. If you are mounting the handheld to a pole, mount it first and then calibrate the compass.

## Communicating with a Desktop Computer

The Allegro 2 can connect to a desktop or laptop computer, allowing you to synchronize information and download software and files.

### Installing the Software

Install free synchronization software from Microsoft® on your desktop computer.

1. Go to the Microsoft® website on your computer at <http://www.microsoft.com/en-us/download/>.



2. If your computer is running Windows® 2000 or Windows® XP, search for and select ActiveSync® software to download. If it is running Windows Vista™, Windows® 7, or Windows® 8, search for and select Windows Mobile® Device Center software.
3. Follow the download instructions on the website.

### Establishing a Partnership

1. Plug the USB Client end (micro B) of the USB communications cable into the Allegro 2.
2. Plug the USB Host end (full size A) of the USB communications cable into your computer.
3. Establish an ActiveSync® or Windows Mobile® Device Center partnership by following the instructions on the computer screen.
4. Once a partnership is established, the synchronization software opens. Follow the steps on the screen.

## Getting Started Application

### Getting Started Screen

The Getting Started screen provides information on current settings, help for setting up features and applications, and shortcuts to set up screens. To see a list of topics press *Start > Getting Started*.

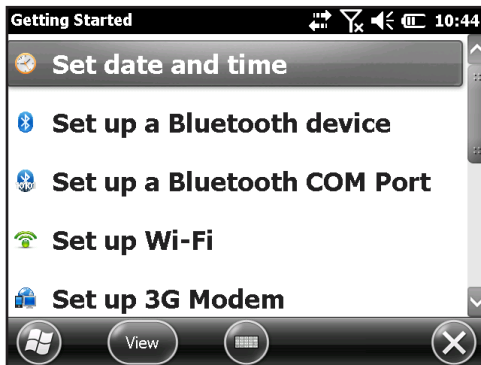

### Information for Software Developers

For Allegro 2 SDK information, go to our website: [www.junipersys.com/Juniper-Systems-Rugged-Handheld-Computers/support/Developers/Allegro-models](http://www.junipersys.com/Juniper-Systems-Rugged-Handheld-Computers/support/Developers/Allegro-models).



# 4 Bluetooth Wireless Communication

## Bluetooth® Wireless Communication

The Allegro 2 has built-in *Bluetooth*® wireless technology, allowing you to connect it to other wireless devices with *Bluetooth* technology. Minimum performance between similar objects in an unobstructed environment is approximately 100 feet (30 meters).

The handheld provides simple configuration options for the following types of *Bluetooth* devices:

- Devices such as headphones, keyboards, and modems (to connect to the Internet with an external cell phone).
- Serial devices that use a *Bluetooth* COM port, such as GPS receivers, bar code scanners, and other data collection devices.

### Creating a Partnership

To create a partnership between the Allegro 2 and another device with *Bluetooth* technology:

1. Turn both devices on.
2. Place them within at least 100 feet (30 meters) of one another.
3. Make *Bluetooth* discoverable on both devices. *Bluetooth* on the Allegro 2 is off by default. To activate it from the Home screen, tap the *Bluetooth* gadget. It turns green when it is discoverable.

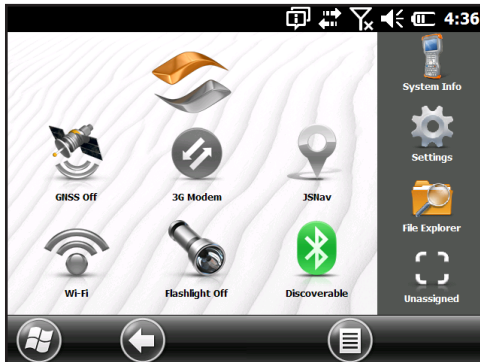

4. You should now be connected to the COM device.

If the *Bluetooth* gadget is not on your Home screen, you can get to the desired control panel by selecting *Getting Started* and either *Set up a Bluetooth device* or *Set up a Bluetooth COM Port*. You can also press *Start > Settings > Connections*.

*Note: If the Bluetooth radio is turned on and then the handheld is suspended, wireless Bluetooth turns off to save battery power. When the Allegro 2 resumes (turns on), the radio turns on automatically.*

## Bluetooth Control Panel

To create a partnership with and connect to other *Bluetooth* devices, such as headphones, keyboards, and modems, follow these steps:

1. Tap-hold the *Bluetooth* icon to bring up the dialog box shown below.

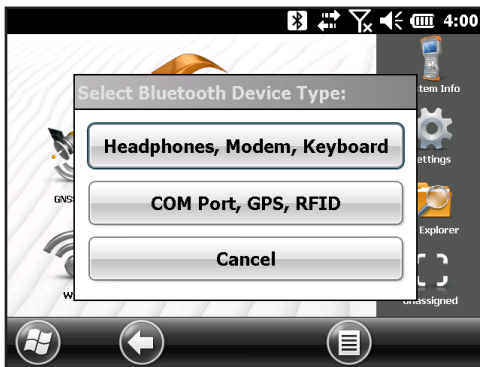

2. Select *Headphones, Modem, Keyboard*. The following *Bluetooth* control panel, *Devices* screen is shown:

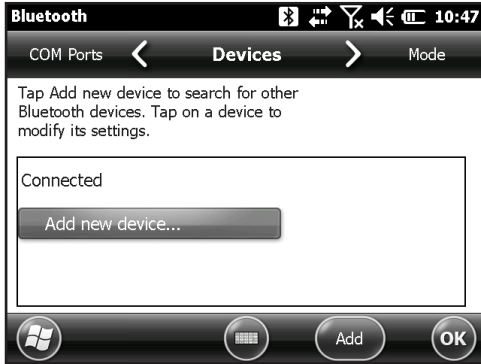

3. Select *Add New Device*. The Allegro 2 searches for other devices with wireless *Bluetooth* technology and displays them in a list. Select the device you want to connect to, and tap *Next*.
4. A passcode screen is shown.

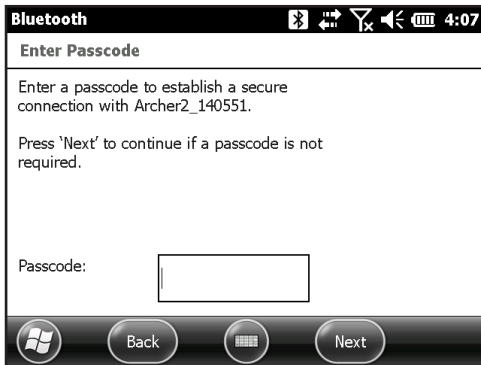

- a. If the device has an assigned passcode, enter the number and press *Next*.
- b. If a passcode is required but has not been assigned, enter an alphanumeric passcode between 1 and 16 characters in length. Press *Next*.
- c. If a passcode is not required, leave the box blank and press *Next*.

Note: If you are unsure whether or not the device requires a passcode and if one has already been assigned to the device, see the user documentation that came with the device.

5. You can adjust the *Bluetooth* settings as needed.

## Serial Device (COM) Control Panel

To set up a *Bluetooth* COM port, follow these steps:

1. Select *COM Port*, *GPS*, *RFID* from the *Bluetooth* dialog box. The following *Bluetooth* COM configuration screen is shown. Select *Discover Devices*.



2. After the handheld searches, a list of discovered devices is shown. Select the device you want to connect to from the list and tap *Connect*. A COM port is automatically assigned for the device. You can change it to another COM port if desired.
3. The Allegro 2 automatically tries to discover the PIN. You might be required to enter a PIN.

You should now be connected to the COM device.





# 5 Wi-Fi Wireless Networking



# Wi-Fi Wireless Networking

The Allegro 2 has built-in Wi-Fi wireless networking to connect to the Internet or a office network.

## Connecting to a Wi-Fi Network

To use Wi-Fi, you need to be in range of a Wi-Fi access point to make a connection. To actively look for a network connection, complete the following steps:

1. From the Home screen, turn Wi-Fi on by selecting the Wi-Fi gadget . The Allegro 2 automatically starts scanning the area for available Wi-Fi networks. (If the Wi-Fi gadget is not on the Home screen, open the Start screen, and select *Getting Started*. Select *Set up Wi-Fi* or press *Start* > *Settings* > *Connections* > *Wireless Manager*.)

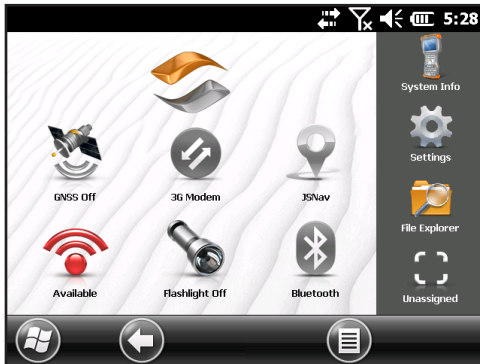

2. Tap-hold the Wi-Fi icon on the Home screen to go to the Wi-Fi control panel. When the handheld completes the scan, a list of available networks and their strengths appears on the Wi-Fi Wireless screen. Click on the

Search for Networks button if none are automatically listed.

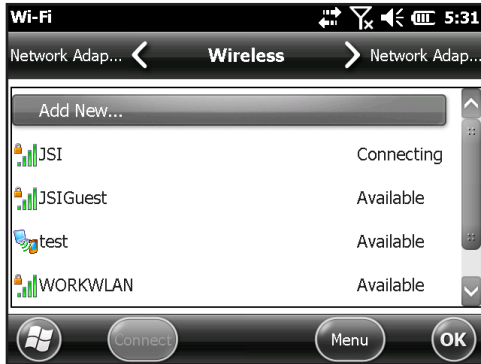

3. Select the network to which you want to connect. If you want to add a new network, select *Add New* from the top of the list.
4. Configuration and authentication setup screens are shown. Depending on the network you are connecting to, you may need to make some selections from pull down lists and enter information like a passkey. Some information may not be required or will appear automatically. When you are finished with the set up screens, press *Finish*.
5. Select *Network Adapters* from the horizontal scrolling menu near the top of the screen. For connection options, select *The Internet* or *Work* (for office networks). Other settings can be modified if necessary.
6. If you selected *The Internet*, you can open Internet Explorer and begin using the Internet.

Once a Wi-Fi network is set up, the icon on the Home Page turns blue and the name of the network is shown.

The Allegro 2 remembers the Wi-Fi network connections created.

### **Wi-Fi Dialog Box**

Whenever Wi-Fi is turned on, a dialog box might appear at the bottom of the screen indicating the Wi-Fi networks the

Allegro 2 has located. You can select a new network from this dialog box without opening the Wi-Fi control panel.



Tap on the screen outside of the dialog box to remove it temporarily. You can also disable it to keep it from appearing in the future. When this dialog box is shown, select the Menu soft key and select *Don't show this message...* from the list.

### **Adjusting Wi-Fi Settings**

To add a new Wi-Fi network or edit settings, open the Wi-Fi control panel, select the Menu soft key, and make desired selections from the pull-down list.



**6**  
**GPS/GNSS**

# GPS/GNSS

Allegro 2 Geo models provide position information using an integrated GPS/GNSS receiver. The camera application uses GPS/GNSS for geotagging pictures, and JSNav uses the GPS/GNSS for logging points and tracks. You may also run other applications that use the position information provided by the GPS/GNSS receiver.

## Using GPS/GNSS

To use GPS/GNSS, tap on the GPS/GNSS status gadget  to turn it on. The GPS/GNSS starts looking for satellites to use for a fix. The green LED on the keyboard blinks periodically, and a satellite icon is placed on the title bar.

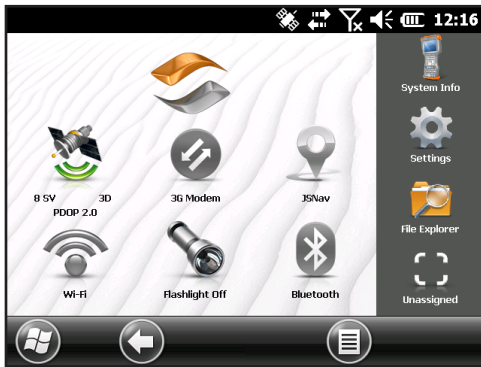

Once enough satellites are found, information similar to the following is shown:

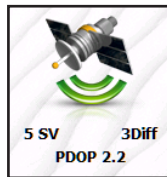

- 5 SV The number of satellites used for the current position.
- 3Ddiff The type of fix you have. Three satellites are required for a 2D fix while four are required for a

3D fix. 3Diff means an SBAS (WAAS/EGNOS/MSAS) signal is being used for the GPS/GNSS solution.

**PDOP** Positional Dilution of Precision is a measure of accuracy. The lower the number, the more accurate the fix.

*Note: When you suspend the Allegro 2, the receiver is in a low power mode to retain its almanac. When you resume, it takes a few seconds to get a fix.*

## GPS/GNSS Accuracy

The GPS/GNSS antenna is in the top of the Allegro 2. Do not put your hand or another object over the top bumper or display. This reduces accuracy. The more items between you and the satellites, the lower the accuracy.

## GPS/GNSS Settings

To view or make changes to the GPS/GNSS settings or set up an external GPS/GNSS receiver, press and hold the GPS/GNSS status gadget on the Home screen to open the GNSS control panel.

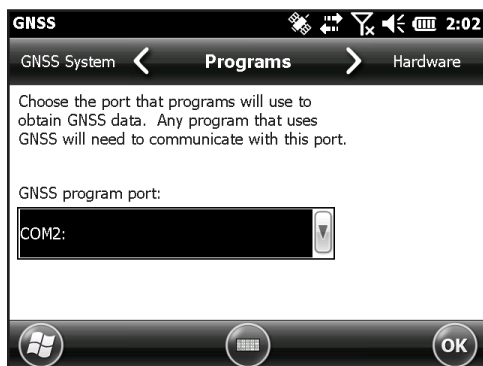

Scroll through the menu and set up the desired parameters. Select from pull-down lists and enable or disable check boxes and circles by selecting or deselecting them.

- **Programs:** Select the program port (COM2 is the default). Several applications can share the COM port setup as the GPS/GNSS program port using the GPS Intermediate

Driver (GPSID). See the section on the *GPS Intermediate Driver* later in this chapter for details.

- **Hardware:** Specify the hardware port your GNSS device is connected to (COM8 is the default) and the baud rate (internal GNSS uses 115200 baud)
- **Access:** Multiple programs can obtain GPS data simultaneously (we recommend that you leave *Manage GPS Automatically* selected)
- **Format:** Select the data format you prefer
- **NMEA Sentences:** See the section on *NMEA Sentences* later in this chapter for details.
- **GNSS System:** Select the satellite systems you want to use (GPS, SBAS, GLONASS) and module settings (update rate, baud rate, static hold, and mode). Restart the GNSS receiver after changing settings.

### **GNSS Static Hold**

The static hold mode is designed to allow you to set a threshold below which the unit will output a stationary position. The values are entered in cm/second, with 45 cm/second being approximately one mile per hour. For example, if the threshold is set to 20 cm/second, you must be moving at a greater speed for the unit to update your position information. If your speed is below that threshold, Static Hold will be activated. If you wish to disable the Static Hold feature, set the threshold to zero.

## GNSS Modes

The Modes setting allows for different dynamic platform models to be used. These adjust the GNSS engine to the expected application. See the table below for mode types and application.

Mode	Application
Portable	Used primarily where speed is not a factor, such as portable devices.
Stationary	Used when the receiver is not moving. Speed may not exceed 0 meters/second.
Pedestrian	Used for low-speed applications such as walking. Default setting.
Automotive	Used where higher speeds may be needed, such as in a moving vehicle.

## GPS Intermediate Driver

The GPS Intermediate Driver (GPSID) is used to allow more than one program to use data from the GPS receiver. The GNSS control panel controls how the GPSID is used. The GPSID can output data on another COM port in a way that allows multiple programs to access the same COM port. This is called the GNSS program port and defaults to COM2. This can be set up on the *Programs* screen of the GNSS control panel.

Internal GPS is on COM8 and communicates at 115200 baud. These settings are found on the *Hardware* screen of the GPS Settings control panel. If another GPS receiver is to be used, this is where you connect that GPS receiver so that the GPSID can access it.

The camera, GPS function, and JSNav application use the GPSID to obtain GPS information. Turning off the GPSID through the GPS hardware port disables these functions.

*Note: If an application accesses the GPS module directly on COM8, the GPSID will not have access to the GPS, preventing camera geotagging and GPS from functioning.*



## NMEA Sentences

Descriptions of the NMEA Sentences shown on the GNSS control panel menu follow.

- *RMC - Recommended Minimum Specific GNSS Data.*  
Example of data output: \$GPRMC,045824.00,A,4127.31350,N,11202.79015,W,00.03,022.9,160914,,,A\*4C.  
The RMC message contains the time, date, position, course and speed data provided by the GNSS navigation receiver.
- *VTG - Course over Ground & Ground Speed.* The VTG message provides actual course (CoG) and speed (SoG) relative to the ground.
- *GGA – Global Positioning System Fix Data.* The GGA message outputs time, position and fix related data. The fix is based on all available GNSS. This message is similar to the GNS – GNSS Fix Data GNS message.
- *GSA – GNSS DOP and Active Satellites.* The GSA message contains the GNSS receiver's operating mode, satellites used for calculation of the PVT data transmitted by the GGA message, and DOP values. The GPS satellites are identified by their PRN, which range from 1 to 32. The WAAS system has numbers 33 to 64 to identify its satellites. The numbers 65 to 95 are used for GLONASS satellites (64 + satellite slot number).
- *GSV – GNSS Satellites In View.* The GSV message identifies the number of satellites (SV) in view, satellites' PRN numbers, elevation, azimuth and SNR value. One GSV message may contain data for one to four satellites. If more than four satellites are in view, then additional GSV messages will be generated. Total number of messages being transmitted and the number of the current message are indicated in the first two fields of the message. If multiple GPS, GLONASS, etc. satellites are in view, then separate GSV messages with Talker ID GP for GPS satellites in view, GL for GLONASS and GA for GALILEO satellites will be generated.
- *GLL – Geographic Position – Latitude/Longitude.* The GLL message contains the latitude and longitude of the present position, the time of the position fix and the status.

- *GNS – GNSS Fix Data.* The GNS message contains Time, Position Fix, and related data for single or combined navigation satellite systems (GNSS). If the data is calculated from multiple satellite systems in differential mode, then several GNS messages are generated. The first message with Talker ID “GN” will be followed by separate messages with Talker ID “GP,” “GL,” etc. to report the data calculated from the individual systems. Only one GNS message is generated in differential mode with SBAS.
- *ZDA – Time & Date.* The ZDA message provides UTC, day, month, year, and local time zone. The Local time zone is presented by the number of hours and minutes that have to be added to local time in order to get the UTC time. Local zone is generally negative for East longitudes with local exceptions near the International Date Line.
- *GBS – RAIM GNSS Satellite Fault Detection.* The GBS message provides results of the Receiver Autonomous Integrity Monitoring (RAIM) function. Given that the GNSS receiver is tracking sufficient satellites to perform integrity checks on the positioning quality of the position solution, a message is required in order to report the output of this process to other systems and advise the system user. With the RAIM function in the GNSS receiver, the receiver can isolate faults to individual satellites and not use these in its position and velocity calculations. Also, the GNSS receiver can still track the satellite(s) and easily judge when returned within tolerance. This message is used for reporting such RAIM information. To perform this integrity function, the GNSS receiver must have at least two observables in addition to the minimum required for navigation. Normally these observables take the form of additional redundant satellites. If only GPS, GLONASS, etc. is used for the reported position solution, the Talker ID is “GP,” “GL,” etc. and the errors pertain to the individual system. If satellites from multiple systems are used to obtain the reported position solution, the Talker ID is “GN” and the errors pertain to the combined solution.
- *DTM – Datum Reference.* The DTM message provides the current local geodetic datum and datum offsets from

the reference datum. The reference Datum cannot be changed and is always WGS 84 for the NV08C receiver.

- *GST – GNSS Pseudo Range Error Statistics.* The GST message reports statistical information on the quality of the position solution. This is represented in standard deviation of error of various position elements.
- *GNSS System Compatibility Mode.* To allow you to use software developed for interfacing GPS-only receivers, a Compatibility mode is included in the communication protocol. In this mode, the Talker ID of GGA, RMC, DTM, GLL, VTG and ZDA messages is set to “GP” regardless of which system satellites are used for the reported position. This also limits the message size output. Position information is limited to 4-digits to the right of the decimal.

### **External GNSS Antenna Port**

An expansion pack door with SMA connector as well as an external L1 antenna are now available to purchase for use with the internal GNSS receiver in the Allegro 2. This provides an additional option for enhanced GNSS accuracy. This expansion pack must be installed at the time of original Allegro 2 purchase, or can be retrofitted onto GEO model units at a certified repair center.



When an external GNSS antenna is attached, the GNSS receiver will automatically detect and use the external antenna. Otherwise, the GNSS receiver will use the internal GNSS antenna.

A compatible external antenna is available from Juniper Systems.

## JSNav Application



JSNav is a GPS/GNSS application that lets you easily collect waypoint or track data.

*Note: Calibrate the compass before you use JSNav. Refer to Chapter 3, Programs and Settings, Compass and Accelerometer.*

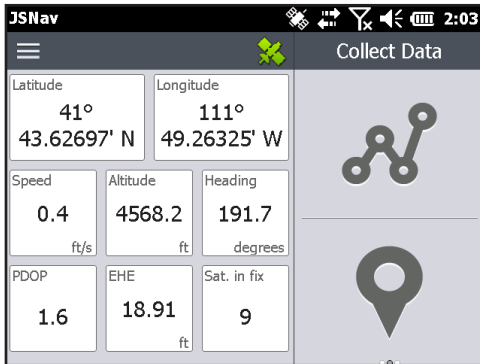
From the Home screen, select the JSNav gadget . A splash screen appears while the application opens, and then the main JSNav screen appears. Select the satellite icon  in the upper right corner to turn GPS on or off. (A gray icon means GPS is not connected, red means there is no fix, yellow means a 2D fix, green means a 3D fix, and blue means a 3D Diff or SBAS fix.)





Once there is a fix (this may take a few minutes) the left portion of the screen shows you information about the current position as well as PDOP (position dilution of precision), EHE (estimated horizontal error), and the number of satellites used for a fix. To view signal strength, swipe this area to the right. To view NMEA output, swipe to the left.

The right portion of the screen is used to collect and view waypoint or track data. Select the waypoint  or track  icon or swipe this portion of the screen to the right or left.

### Use the Touchscreen or Keyboard with JSNav

You can use the touchscreen or the keyboard to move around the JSNav screens and make selections. There are also shortcut key combinations unique to JSNav. To see

them on the screen, select the menu icon , then **?** Info or the  + I keys.



## JSNav Settings

Tap on the menu icon  in the upper-left corner of the screen, and select *Settings* from the list. Go through the menu options to set up JSNav.

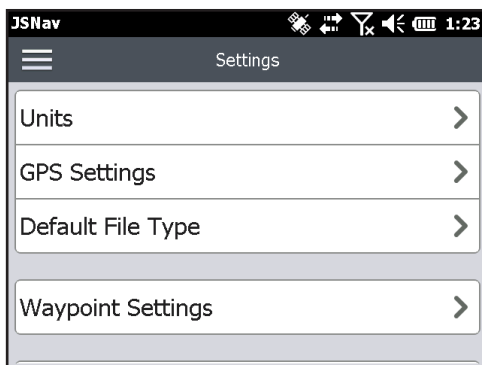

*Note: These settings only impact the JSNav application. To set up GPS/GNSS, go to the GNSS Settings control panel discussed earlier in this chapter.*

- **Units:** Select English or metric units of measurement and the display format for latitude and longitude.
- **GPS Settings:** Select the maximum PDOP for collecting points, minimum navigation speed you need to be traveling for navigation to update properly, and the navigation distance threshold. This is the distance you

can be from the point to which you are navigating to show that you have arrived.

- **Default File Type:** Select .kml (keyhole markup language used in Google Earth) or .csv (comma separated value). Note that tracks with more than 1000 points default to .csv due to memory limitations.
- **Waypoint Settings:** Set up the waypoint file naming scheme, including the waypoint prefix, increment step size, and current value. For example, if the waypoint prefix is Point, increment step size is 10, current value is 100, and default file type is .kml, file names would be Point110.kml, Point120.kml, Point130.kml, etc.) Also select the number of points to average. The default is 1.
- **Track Settings:** Set up the track file naming scheme (see Waypoint Settings). You can select a minimum time and minimum distance needed before a point is collected. If both are enabled, both conditions must be met before a point is added to a track. You can disable suspend when track points are being collected.
- **Audio Notifications:** You can turn on notifications for waypoint arrival, waypoint collected, and track point collected.

Some settings can be customized for a particular waypoint or track using edit  on the data collection screens.



### **View Signal Strength and NMEA Strings**

View the strength of satellites being used in a fix (shown in green) by swiping the left side of the display (where position is shown) on the JNav Home screen to the right. View the NMEA strings that are coming in through the GNSS receiver by swiping the same area to the left. Strings can be saved to a file.

## Collect Waypoint Data

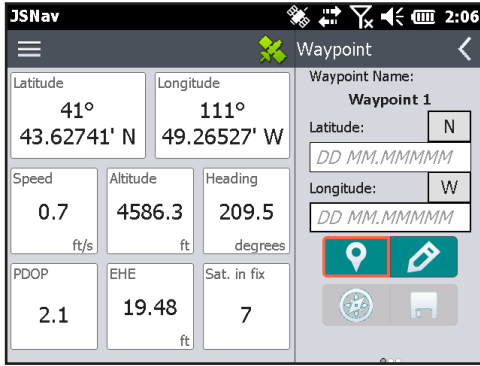
From the main JSNav screen, select the waypoint  icon to open the *Collect Waypoint* screen.



- To collect a waypoint, select the waypoint  icon at the bottom of the screen. Position information for the waypoint is recorded.
- Select the edit  icon to add or edit the name, description, notes, and file type for this waypoint.
- To navigate back to the waypoint you just collected, select the compass  icon. A rotating compass is shown.

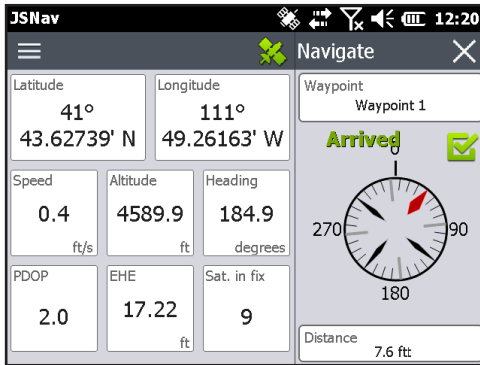

Walk in the direction of the red arrow. The distance shown decreases as you get closer. Text saying *Arrived* is shown and you hear a beep (if audio notifications are set up)

when you reach the navigation distance threshold set up in GPS Settings.





*Note: When moving, the compass shows the direction of travel to the target. When stationary, the compass displays a heading to the target, based on the internal compass. The internal compass can be calibrated from the Settings menu located at Start > Settings > System > Sensors.*

- Select the disc  icon to save the waypoint to \My Documents\My Waypoints.

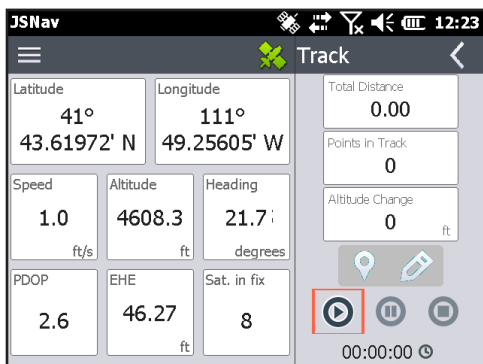
## Collect Track Data

From the main JSNav screen select the track  icon to open the *Collect Track* screen.







- To collect points in a track, select the play  key and start moving along the desired track. Select the pause  key as needed, and select play to start again. Current position information, total distance, altitude change, and points in the track are collected.
- When you are finished, select the stop  key. A dialog box is shown with the track name. You can use that name or edit it. Select the check mark when you are finished. The track is saved in \My Documents\My Tracks.
- Select the edit  icon to add or edit the name, description, notes, and file type for this track



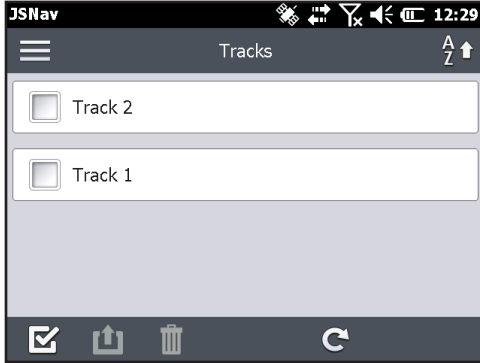



## Manage Waypoints and Tracks

To view the waypoints and tracks you have saved, select the menu  icon, then select *Waypoints* or *Tracks* from the menu. A list of waypoints or tracks is shown.

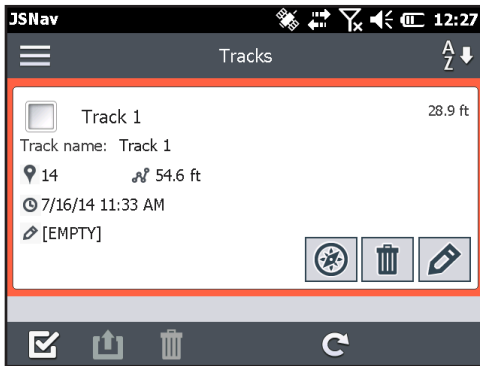

To open a file, select the name. You can view collected data, select the file for exporting or deletion by selecting the box to the left of the name, navigate back to the waypoint or track points , delete the file , or edit  the file.



To select all of the files, tap the check box  at the bottom of the screen. You can delete  or export  all selected files. Exported files are placed into a directory called Exports inside of your *\My Documents* folder.

## Importing Waypoints and Tracks

Waypoint and track file formats must be .kml, .kmz or .csv. CSV files must contain a column for both latitude and longitude.

To import a waypoint or track file, place the file into the `\My Documents\My Waypoints` or `\My Tracks` directory. You can create subdirectories to organize your data if you want. Once you place a waypoint or track file into the proper directory or subdirectory, it appears in the list of files.

An imported track file can only contain one track if you are going to navigate to a specific track. If a file contains multiple tracks, a key inside of JSNav is available to extract the tracks into separate files.

## Navigating to a Waypoint or Track

You can navigate back to any saved waypoint or track. Select the file you want to navigate to as described in the previous section, *Managing Waypoints and Tracks*. Select the compass  icon.

A rotating compass is shown. Travel in the direction of the red arrow. The distance shown decreases as you get closer. When you reach the navigation distance threshold set up in the settings, text saying *Arrived* is shown and you hear a beep if audio notification has been set up.

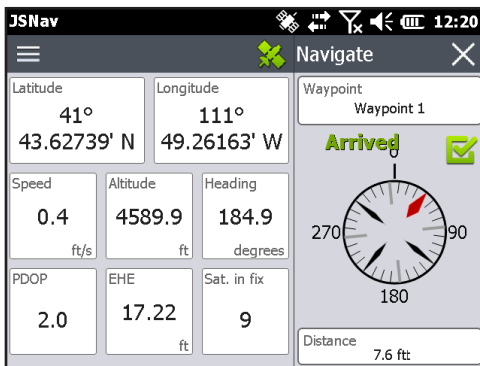





# 7 Camera

## Camera

Allegro 2 Geo models have a 5MP camera. Juniper Geotagging™ gives you the ability to embed and emboss photos with the date, time, and GPS position.

The camera window and flash are located on the back of the Allegro 2.



*Note: The flash can also be used as a flashlight. See Chapter 2, Hardware Components, Flashlight.*

## Camera Settings for Still Images

Press the orange  + **C** keys to turn the camera on and open the Pictures and Videos application.

### Pictures Menu

Select the *Menu* soft key for a pull-down list of setting options. View or change the settings before you take photos. These settings will apply to all photos taken, but can be edited as needed.

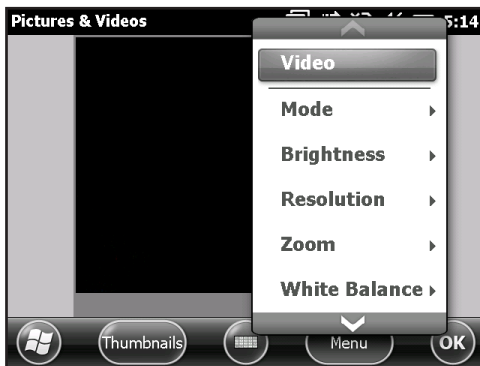

## Flash

To use the flash, select *Flash* from the *Menu*, then select *On*. The flash automatically turns on each time you take a photo. To turn it off, select *Flash* from the menu and select *Off*.

## Pictures & Videos Control Panel

To view or change additional settings, select *Options* from the *Menu* soft key. The Camera control panel is shown. Use the horizontal scrolling menu near the top of the screen to see what the settings are and make changes as needed.

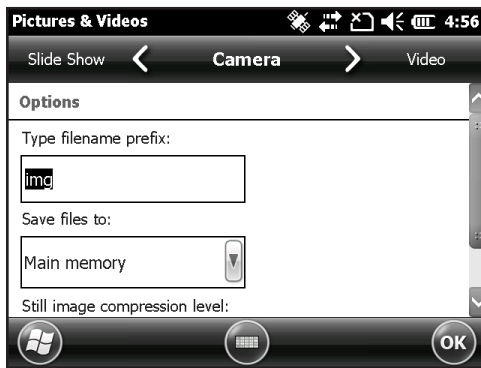

## Geotagging

When pictures are geotagged, the date, time, latitude, longitude, file name, and notes can be included with the pictures with the emboss and embed options.

*Note: Calibrate the compass and accelerometer before you use Geotagging. Refer to Chapter 3, Programs and Settings, Compass and Accelerometer.*

Follow these steps:

1. Turn on GPS by selecting the GPS gadget  on the Home screen and waiting for a fix.

2. Select the *Menu* soft key, then select *Geotag* from the menu. The following *Emboss Options* screen is shown:

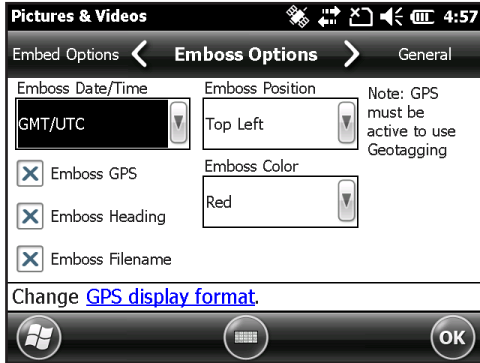

3. Select the information you want to emboss on pictures, the position, and the color.
4. The selected information is embossed on pictures, making it part of the images.

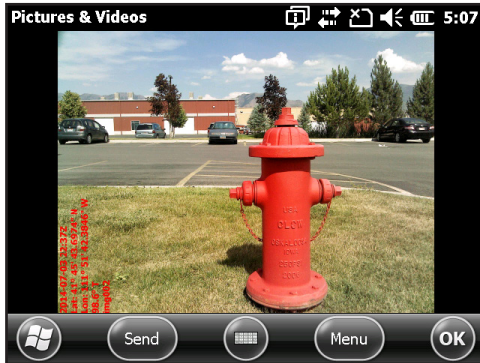

5. You can build GPS information into jpg files from the *Embed Options* screen. (This information does not appear on the images.) You can select *Use True North*.

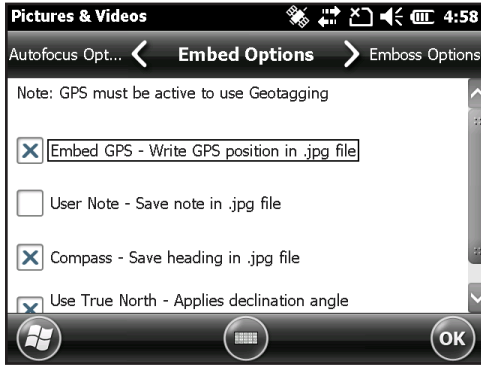

6. *Embed GPS* allows you to put images into programs like Google Earth™ and sort them by location, etc. If you select *User Note*, the note screen is shown after a photo is taken. Enter a note for the image and press *OK*.

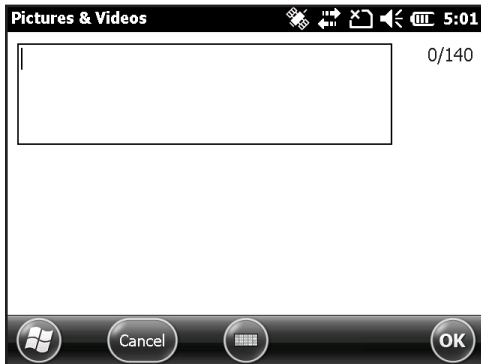



## Take Photos and Select Photo Options

Press the **□** + **C** keys to turn the camera on. Frame the photo as desired and press the action **Ⓢ** key or the return key **↵**. A square yellow box is shown indicating that the camera is focusing. Press enter when you are ready to take the picture. A screen like the following is shown for a few seconds. Hold the handheld steady until you hear a click, indicating that the photo has been taken.

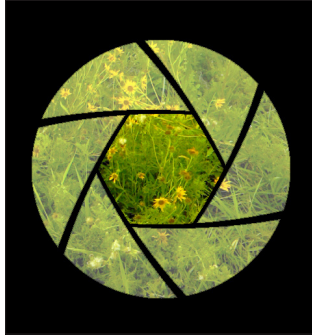

*Note: The built-in accelerometer is used to detect the handheld orientation when the picture is snapped and save the image in the right orientation.*

While the photo is being saved, a disk symbol is shown briefly. The full photo is then shown on the screen.

### Photo Options

Select the Menu soft key to see a list of options for a particular photo. (The photo must appear on the screen.)

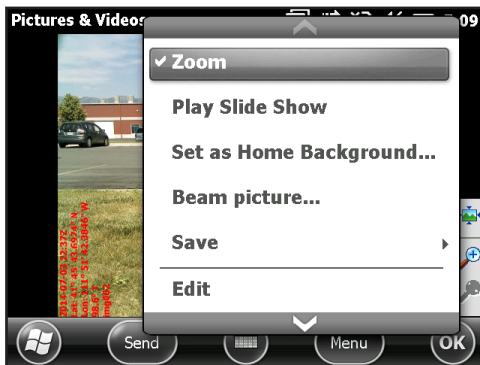

To take another photo, press the *Camera* soft key. To see a library of photos and pictures, press *Thumbnails*.

## Videos

Press the **□** + **C** keys to turn the camera on. Select the *Menu* soft key, and select *Video*.

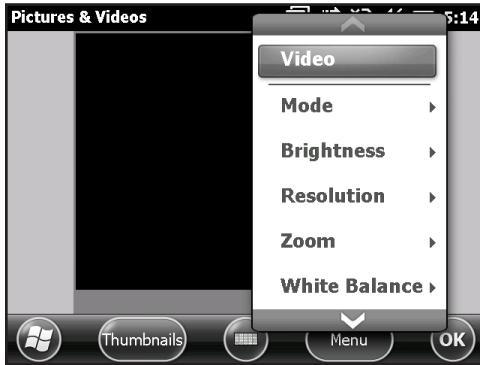

Select *Menu* again to view and adjust settings as desired.

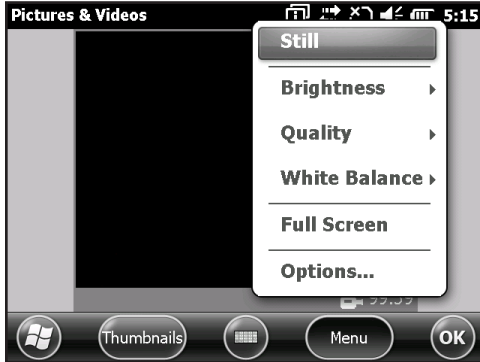

Press the action **⊕** key or the return key **↵** to start recording a video. Press the key again to end the video.

*Note: To take photos instead of videos, select *Menu* and select *Still* (see previous screen).*

## Audio

You can record sound with videos. From the Pictures & Videos application screen, tap *Menu > Video > Menu > Options*. From the Video screen, tap *Include audio when recording video files* to turn audio on.

## Photo and Video Library

To view your photo and video library, select the *Thumbnails* soft key from the Pictures and Videos application screen.

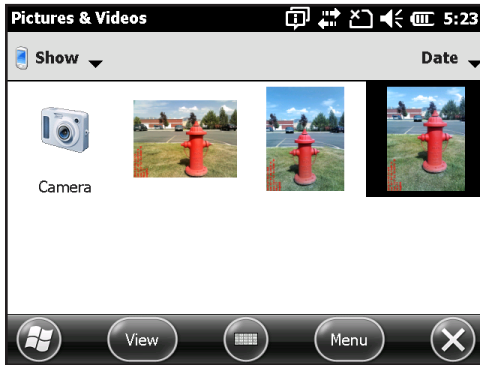

## Library Menu Options

Select a photo or video, then the *Menu* soft key. You can send, delete, edit, etc. the selected photo or video.

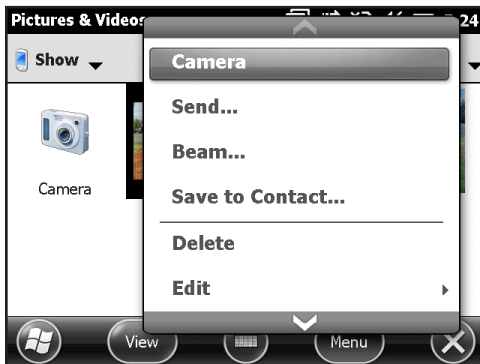



# 8 3G Data Modem

## 3G Data Modem

The 3G data modem is an option for Allegro 2 Geo models, adding Wide Area Network data modem capability. The modem is installed at the factory.

The modem is a cellular data modem, type GSM/UMTS. It is five band modem compatible. The modem operates in different modes, depending on the wireless provider and the signal strength. Data speeds vary anywhere from 10 or 20 Kbps when using GPRS to over 1 Mbps when using HSDPA.

## GSM Modem

The GSM modem is a cellular data modem, type GSM/UMTS. It provides data transmission in the United States, as well as internationally.

### Set up a Data Account with a Wireless Provider

Contact a wireless provider to set up data service for the cellular data modem and obtain an account and mini SIM card (purchased separately). You need to provide the following information when setting up an account:

1. Billing Information and business ID, such as your Federal Tax I.D. or VAT number.
2. The wireless services required. Specify that you need data service only. You do not need voice or messaging services.
3. You may be asked for the modem's IMEI number, which can be found here: Start > Settings > System > System Information > 3G Modem with the modem powered on.
4. You may be asked to provide the modem's model number. This number allows the carrier to verify this modem as one of its approved models. If asked for this by the carrier, it is a Juniper Systems Allegro 2.

### Install the SIM Card

To insert or remove a card, follow these steps:



**CAUTION:** Always power off the handheld before removing the battery. Failure to do so may cause loss of data or damage to the handheld.

1. Power off the handheld by holding the power button until the Power Button menu appears and selecting Power Off. Ensure that your unit is not plugged in to external power.
2. The mini SIM card slot is located in the battery compartment. Loosen the screws to the door and remove it.



**CAUTION:** Do not use a micro SIM adapter. The adapter can get stuck and damage the slot.

3. Remove the battery pack.



**CAUTION:** The Allegro 2 is not sealed against water and dust when the battery door is not installed.

4. An image on the battery compartment label shows the correct location and orientation for the mini SIM card. Pull out the SIM card tray. Place the card onto the tray and push the tray in until it catches.



To remove the SIM card, pull the tray open and remove the card. Push the empty tray in until it catches.

5. Replace the battery pack, and attach the battery door.
6. Power on the Allegro 2.

*Note: If the modem was on before shutting the Allegro 2 down to insert the SIM card, you are prompted to configure the data connection when you reboot. See the instructions on the following pages.*

## Set up the GSM Modem

Tap on the 3G modem gadget . After about 30 seconds it turns green, indicating that the modem is available.

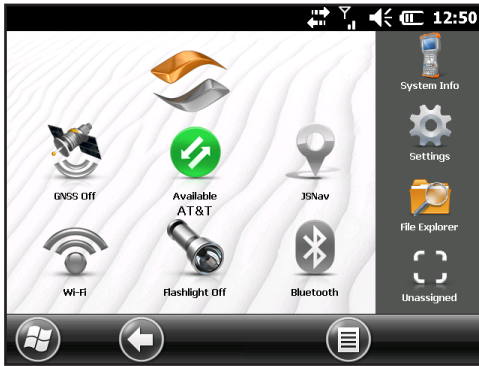

Once the modem is available, configure it to make a connection. Tap and hold the modem gadget to open the Connections control panel.

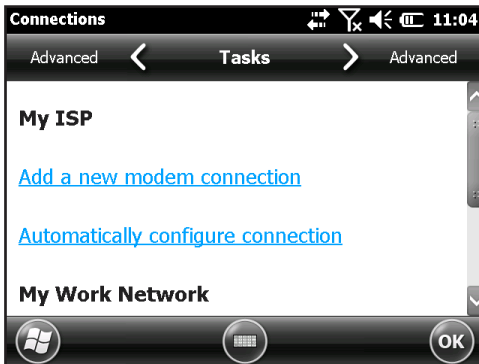

Select **Automatically configure connection**. The name of your carrier appears. Select **Next**. A progress graphic is shown on the next screen while your Internet settings are configured.

You can now access the Internet. Open Internet Explorer to test your setup.

### **Connection Problems**

If the connection fails to automatically configure, there might not be a signal where you are located. You can try repeating the set up process.

## **Wireless Safety**

### **RF Interference Issues**

It is important to follow any special regulations regarding the use of radio equipment due in particular to the possibility of radio frequency (RF), interference. Follow the safety advice given below carefully.

- Switch OFF your cell modem when in an aircraft. The use of cellular telephones in an aircraft may endanger the operation of the aircraft, disrupt the cellular network and is illegal.
- Switch OFF your cell modem in hospitals and any other place where medical equipment may be in use.
- Respect restrictions on the use of radio equipment in fuel depots, chemical plants or where blasting operations are in progress.
- Operating your cell modem close to inadequately protected personal medical devices, such as hearing aids and pacemakers, could be hazardous. Consult the manufacturers of the medical device to determine if it is adequately protected.
- Operation of your cell modem close to other electronic equipment may also cause interference if the equipment is inadequately protected. Observe any warning signs and manufacturers' recommendations.
- Do not place the cell modem alongside computer discs, credit or travel cards, or other magnetic media. The modem may affect the information contained on discs or cards.

### **Maintenance of Your Modem**

Do not attempt to disassemble the cell modem. No user serviceable parts exist inside the cell modem.







# 9 Barcode Scanner

# Barcode Scanner

The Allegro 2 Rugged Handheld with a barcode scanner allows you to read 1D and 2D barcodes and easily import barcode data into custom or standard programs running on the Allegro 2.



## Quick Start – Easily Scan a Barcode Now

When you receive your Allegro 2 with the barcode scanner, you can scan a barcode right away using the default settings. Follow these steps:

1. Find a barcode to scan (or use this one):



2. If the battery pack has not been charged, plug the AC wall power charger into a wall socket. Plug the other end into the DC power jack on the Allegro 2.
3. The handheld powers on and a progress indicator is shown on the screen.
4. The Barcode Connector™ utility automatically opens. Minimize the main screen by pressing the X soft key in the bottom right corner of the screen. The Home screen is shown.

*Note: If the Barcode Connector utility does not automatically open when the handheld is powered on, select the Barcode Connector icon from the favorites bar on the Home screen. If this icon is not shown on the Home screen, tap the Windows start screen soft key  to locate and select the utility.*

To configure a button to use for the scan operation, see *Programmable Keys* in Chapter 2.

5. Open a document to receive the barcode data. (The Notes application is provided on the Allegro 2.)
6. Put the cursor where you want the barcode data to be placed.
7. Using the red crosshairs, aim the scanner at the barcode you are scanning. Press the button you programmed as Barcode Scan to begin scanning.
8. When the scanner decodes the barcode, the data is placed in your document. (With Excel, tap on the column you want the data to appear in.)

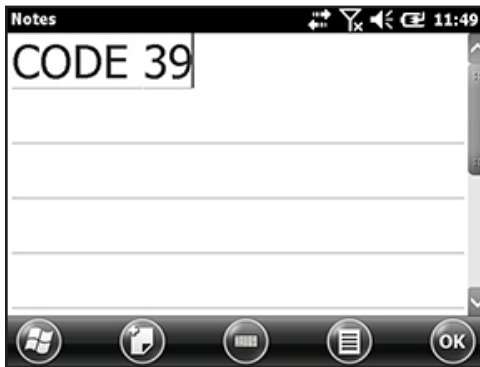

# Barcode Connector Utility

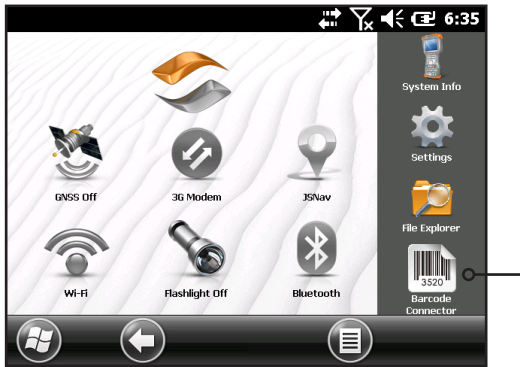

The Barcode Connector™ utility is a barcode wedge program provided with the barcode scanner. Depending on the configuration of your Allegro 2, it either loads automatically when the handheld is turned on or you can open it from the Home screen.

*Note: If the program does not appear in the Home screen favorites bar as shown above (lower right-hand corner), tap the Windows Start screen key  and find it in the Start menu.*

When the Barcode Connector utility loads, the main screen appears:

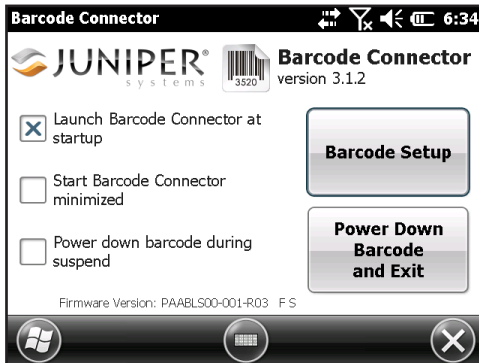

You can select three options, depending on how you want the Barcode Connector utility and barcode to behave during startup and suspend. Tap on the check boxes to turn options on or off.

Two main functions are accessed from here:

- Barcode Setup – Use the setup screens to configure the settings of the barcode hardware and Barcode Connector utility.
- Power Down Barcode and Exit – This function shuts down the barcode scanner. You may want to do this to prevent accidental triggering of a scan sequence. Otherwise, we recommend that you leave it powered on. The barcode is configured to enter a sleep state when it is inactive and consumes about 8mW of power when it is in this state.

To minimize the Barcode Connector utility, press the X soft key in the bottom right corner of the display.

## Barcode Setup

When you select *Barcode Setup*, The Barcode Connector control panel is displayed. Near the top of the screen is a horizontal scrolling menu. Depending on the size of the menu, a vertical scroll bar may be displayed as well. Select screens from the menu to view or edit the configurations for the Barcode Connector utility and the barcode hardware. A description of these screens follows.

### User Screen

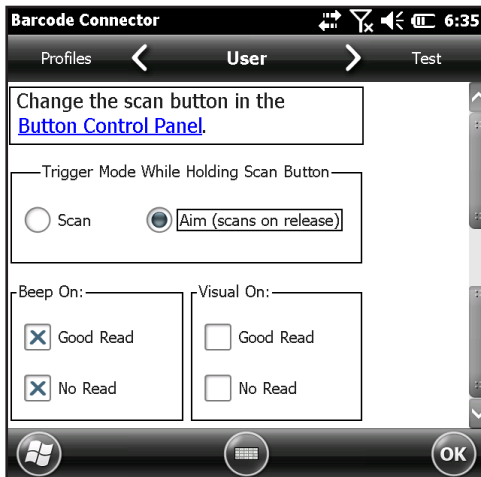

The *User* screen has the following functions:

- Button Control Panel – Select the hyperlink to view the

Button Control Panel. For more information on how to use the Button Control Panel, see *Programmable Keys* in Chapter 2.

- Trigger Mode While Holding Scan Button – Select *Scan* to start scanning the moment the button is pressed. Select *Aim* to turn on the aimer when the button is pressed and to start scanning when the button is released.
- Beep On and Visual On – Select options for audio and visual indicators based on good or bad scan reads.

### ***Test Screen***

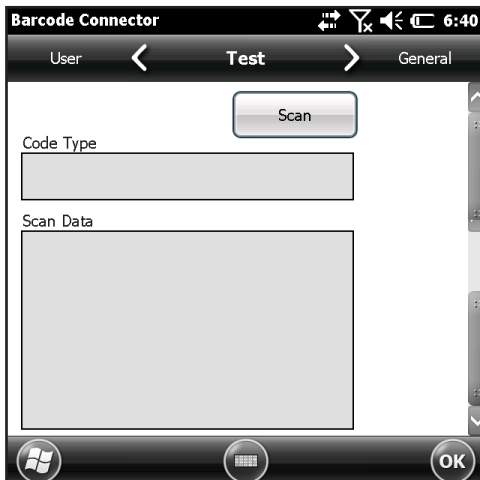

The *Test* screen has the following functions:

- Scan – Tap *Scan* to test the settings and to view information about a scanned barcode. The button you set up on the keypad can also be used.
- Code Type and Scan Data – After a successful scan, the barcode code type and the scan data are displayed.

## General Screen

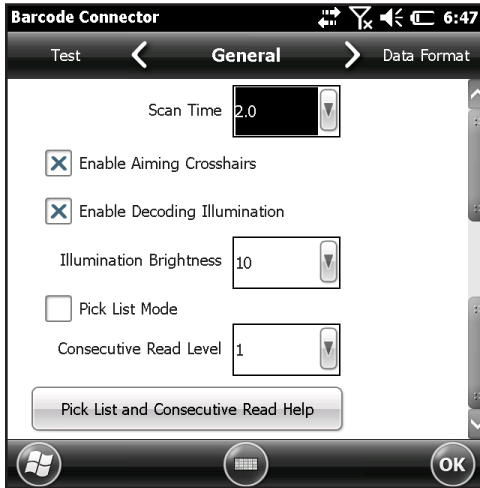

The *General* screen has the following functions:

- Scan Time – Adjust the scan time, which is the duration of time before the scanner times out. This is adjustable from 0.5 to 9.9 seconds, with 2 seconds as the default.
- Enable or disable Aiming Crosshairs.
- Enable or disable Decoding Illumination (red light).
- Illumination Brightness – For better barcode performance, we recommended that you leave illumination brightness at the maximum value of 10.
- Pick List Mode – Enable this mode if barcodes are close together. The scanner only decodes barcodes aligned directly under the center of the aiming crosshairs. Disable this mode if only one barcode is viewable. When disabled, the aiming crosshairs do not have to line up directly on the barcode in order for the scanner to read it. Just aim the scanner in the general area where the barcode is located. This can be helpful in situations where it might be difficult to precisely aim the scanner, such as in locations with bright sunlight.
- Consecutive Read Level – Select how many successful consecutive reads the barcode must get before being decoded.



## Data Format Screen

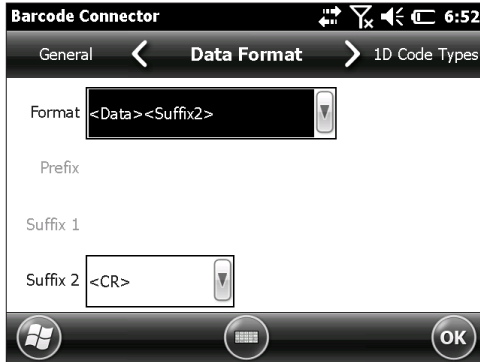

The Data Format screen has the following function:

- Select optional prefixes and suffixes from the *Format* pull-down list to add to the scan data. If you use a program like Excel, we recommend that you select <Data><Suffix1> with Suffix1 set to a carriage return (<CR>). This puts each scan on a new line.

## 1D Code Types Screen

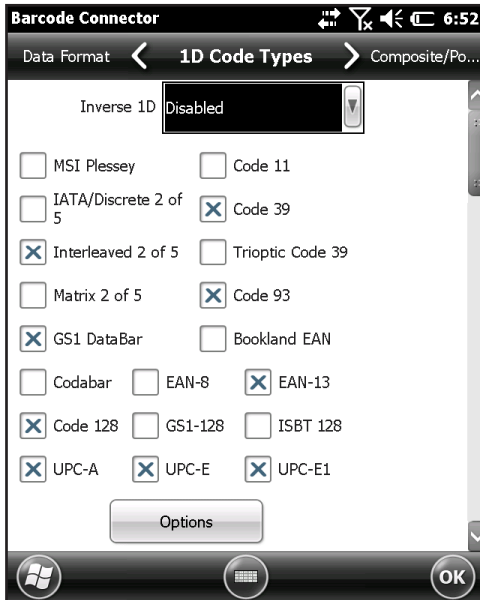

The *1D Code Types* screen has the following functions:

- Inverse 1D – Enable/disable inverse 1D bar codes or select *Auto Detect*.
- Enable/disable the 1D code types listed.

Tap Options to configure 1D code type specific settings. A horizontal scrolling menu is shown near the top of the screen with options for Code 39, Code 128/Code 93/Discrete, UPC/EAN 1, UPC/EAN 2, Interleaved GS1 DataBar, MSI Plessey, Codabar/Code 11, and Matrix 2 of 5. Depending on which 1D barcodes you are going to read, you should review the options and configure them for your needs.

For example, the screen for Code 39 follows:



**Set Length:** This option allows you to specify the length of the barcodes you want to read. This could be useful if you know that all valid barcodes will be a specific length or a range of lengths.

You can specify four barcode lengths (let A refer to the first length field and B refer to the second length field):

- One Discrete Length – Set A to the discrete length and B to 0. Only barcodes with an exact length of A are decoded.
- Two Discrete Lengths – Set A greater than B (both non-zero). Only barcodes with lengths A or B are decoded.
- Length Within Range – Set A less than B (both non-zero). Barcodes between and including A and B are decoded.
- Any length – Set A to 0. Any barcode length is decoded.

## Composite/Postal Code Types Screen

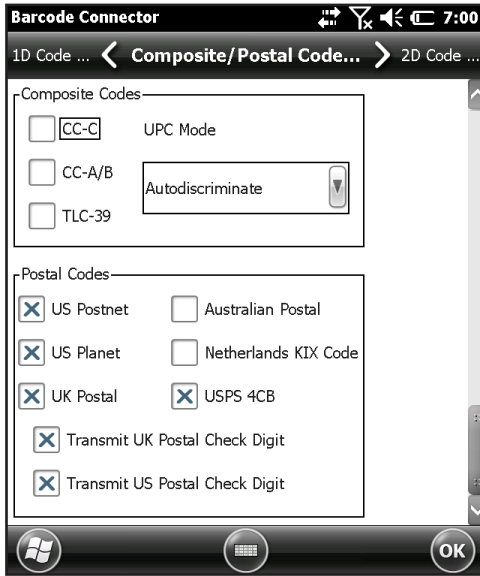

The *Composite/Postal Code Types* screen has the following functions:

- Composite Codes - Enable or disable composite code types.
- Postal Codes - Enable or disable postal code types.

## 2D Code Types Screen

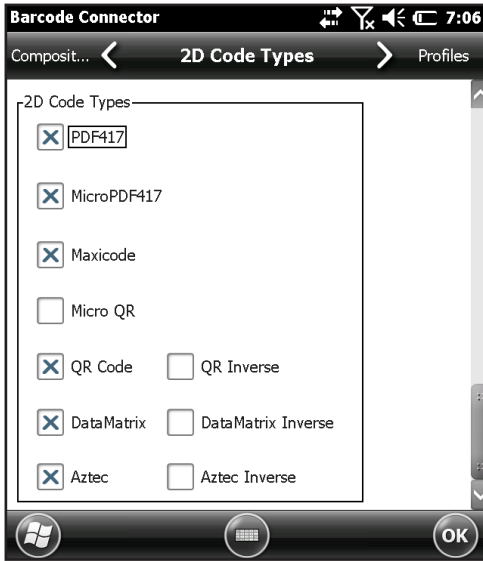

The 2D Code Types screen has the following function:

- 2D Code Types - Enable or disable 2D code types.

## Profiles Screen



The Profiles screen has the following functions:

- Select a Profile to Save or Load - A profile is a saved set of settings. To load a profile, select the profile from the drop-down list and select Load.

*Note: When a setting is changed, a hidden profile (called "last user") is updated. When this utility is launched, it loads the settings from the last user profile.*

Up to four profiles with different settings can be saved.

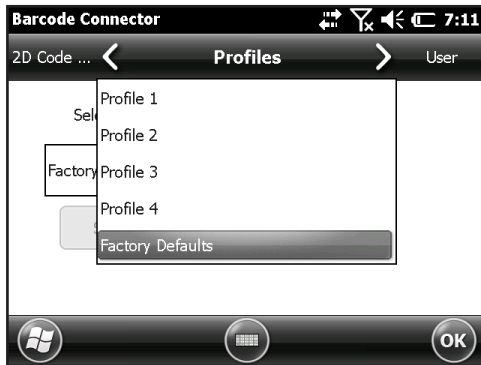

To save a new profile, configure the settings previously discussed, come to this screen, select the profile name you want to use, and select *Save*.

*Note: Any changes to settings after a profile is loaded will not automatically get saved out to the profile, but will get saved out to "last user."*

## Barcode Troubleshooting

1. When I read a barcode, the data returned is not correct.

*Reason/Solution:* Ensure that the configurations are set up correctly so you are given the information you need. For example, to read a Code 32 barcode, on the *1D Code Type* tab, ensure that Code 39 is selected. Select *Options*, and on the Code 39 tab ensure that *Convert Code 39 to Code 32* is selected.

2. I don't know what type of barcode I am trying to scan.

*Reason/Solution:* Enable all the barcode types on the *1D Code Types*, *Composite/Postal Code Types*, and *2D Code Types* tabs (some types are mutually exclusive). Go to the *Test* screen. Scan the barcode and the *Code Type* window shows the type of barcode scanned. When you are finished, go back and deselect barcode types you are not using.

3. My TLC-39 Composite barcode will not scan.

*Reason/Solution:* On the *1D Code Types* screen ensure that *Code 39* is checked. Also select *Options*, then the *Code 39* screen and ensure that *Convert Code 39 to Code 32* is unchecked.

4. My UPC barcode will not scan.

*Reason/Solution:* On the *1D Code Types* screen ensure that barcode types *UPC-A*, *UPC-E* and *UPC-E1* are checked. If composite codes are also enabled on the *Composite/Postal Code Types* screen and you still want to allow a UPC 1D to scan, select *Autodiscriminate* from the drop down list. Also go to the *1D Code Types* screen, select *Options*, then the tabs for *UPC/EAN-1* and *UPC/EAN-2*. Make sure the settings are correct for your application.

5. My Code 39 Full ASCII barcode will not scan.

*Reason/Solution:* On the *1D Code Type* screen, select *Options*, then the *Code 39* screen. Ensure that the lengths are set to the fullest range.

6. My Bookland EAN barcode will not scan.

*Reason/Solution:* Ensure that both *Bookland EAN* and *EAN-13* are enabled on the *1D Code Types* screen.

7. My ISBN, ISMN, ISSN, or JAN barcodes will not scan.

*Reason/Solution:* These barcode types are all subsets of *EAN-13*. Ensure that *EAN-13* is enabled on the *1D Code Types* screen.

8. I can't figure out how to configure Intelligent Mail or OneMail barcodes.

*Reason/Solution:* Intelligent Mail and OneMail barcodes are the same thing. They are also called USPS 4CB (located on the *Composite/Postal Code Types* screen).

9. CLSI editing has no effect.

*Reason/Solution:* CLSI editing is only supported for 14 character Codabar barcodes.

## Sample 1D Barcodes



\*123456789\*

*Code 39*



Juniper Systems, Inc.

*Code 128*



0 001234 567895

*UPC-A*

## Sample 2D Barcodes



*Aztec*

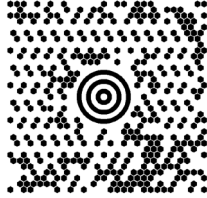

*Maxicode*



*MicroPDF417*



*QR Code*







# A Storage, Maintenance and Recycling

# Storage, Maintenance, and Recycling

Follow the instructions in this chapter to properly maintain and recycle the Allegro 2.

## Storing the Allegro 2 and Battery Pack

When the handheld is not being charged and is suspended, it draws a small amount of power. This power draw is used to maintain the memory (RAM) of the handheld in the same state it was when it was suspended. We recommend charging the handheld each night or weekend when it is in suspend mode.

If the Allegro 2 is not charged while in suspend mode and the battery reaches a low charge, it automatically powers off to prevent further drain on the battery.

*Note: Data and programs are secure as long as they have been saved, even if the battery pack becomes discharged. The handheld does not depend on the battery to store the data for extended periods.*

## Storing the Allegro 2 for Less Than Two Weeks

To store the handheld for less than two weeks, complete the following steps:

1. Close all applications.
2. Plug the handheld into the AC wall adapter that was shipped with your unit.

## Storing the Allegro 2 for More than Two Weeks

To store the handheld for two weeks or more, complete the following steps:

1. Charge the battery pack 30 to 50 percent.
2. Close all running programs, and turn off the handheld.



**CAUTION:** Always perform Power Off before removing battery. Failure to do so may cause loss of data or damage to handheld.

3. Remove the battery pack.
4. Place the battery pack in a dry location.

## Protecting the Touchscreen

Protect the touchscreen from impact, pressure, or abrasive substances that could damage it. To further protect the touchscreen, apply a screen protector (optional accessory). To apply a screen protector, follow the directions that come with it in the package.



- ⓘ **CAUTION:** Be sure to replace the screen protector as often as the screen protector instructions recommend.

## Cleaning the Allegro 2

### Touchscreen

1. Disable the touchscreen by pressing the power key  until the Power Key menu appears. Tap on *Disable TS*.
2. Remove the screen protector if you want to clean underneath it.
3. Apply warm water or a mild cleaning solution to a microfiber cloth and gently wipe off the touchscreen.

- ⓘ **CAUTION:** Do not use tissues, paper towels, soft bristle brushes, or harsh cleaning solutions on the touchscreen.

4. Rinse the touchscreen with water and dry it with a microfiber cloth.
5. Apply a screen protector if you want to (not included). To clean a screen protector, follow the instructions provided with the package.
6. To enable the touchscreen, press and hold the power key  to display the Power Key menu. Use the down arrow key  to highlight *Enable TS*, and press enter .

### Case, Bumpers, and Connector Module

Make sure the battery door is securely installed. Use warm water, a mild cleaning solution, and a soft bristle brush to clean the case, bumpers, and connector module.

- ⓘ **CAUTION:** Do not direct a high-pressure stream of water at the device to clean it. This action could break the seal, causing water to get inside the device and voiding the warranty.

### ***Safe Cleaners to Use***

You can clean the Allegro 2 safely with the following cleaners:

- Windex® (S.C. Johnson & Son, Inc.)
- Formula 409® (Clorox)
- Citrus Wonder, Organic Cleaner (Mer-Maids)
- Citrus All Purpose Cleaner (Wonder Tablitz)
- Greased Lightening® Multi-Purpose Cleaner and Degreaser
- Orange Clean® (Orange Glo International)
- Fantastik® OxyPower® (S.C. Johnson @ Son, Inc.)
- Oil Eater Orange Cleaner Citrus Degreaser (Kafko Intl., Ltd.)



**CAUTION:** Exposure to some cleaning solutions may damage your device, including automotive brake cleaner, isopropyl alcohol, carburetor cleaner, and similar solutions. If you are uncertain about the strength or effect of a cleaner, apply a small amount to a less visible location as a test. If any visual change becomes apparent, promptly rinse and wash with a known mild cleaning solution.

### **Recycling the Allegro 2 and Batteries**

When the Allegro 2 reaches the end of its life, it must not be disposed of with municipal waste. It is your responsibility to dispose of your waste equipment by handing it over to a designated collection point for the recycling of waste electrical and electronic equipment. If you cannot find a location, contact Juniper Systems for information about disposal.

The Li-Ion battery packs for your Allegro 2 are recyclable. Avoid placing them in the trash or municipal waste system. To find the nearest battery recycling center in the USA, you can contact the Rechargeable Battery Recycling Corporation's at 1-877-723-1297.



# B Warranty and Repair Information

## Limited Product Warranty

Juniper Systems, Inc. ("JS") warrants that the Allegro 2 Rugged Handheld shall be free from defects in materials and workmanship, under normal intended use, for a period of 24 months from the date of shipment.

JS warrants that the following items shall be free from defects in materials and workmanship, under normal intended use, for a period of ninety (90) days from the date of shipment:

- battery packs,
- media containing the Allegro 2 programs,
- desktop computer programs,
- user documentation, and
- accessories.

## Warranty Exclusions

This warranty shall not apply if:

- (i) the product has been set up improperly or has been improperly installed or calibrated,
- (ii) the product is operated in a manner that is not in accordance with the user documentation,
- (iii) the product is used for a purpose other than for which it was designed,
- (iv) the product has been used in environmental conditions outside of those specified for the product,
- (v) the product has been subject to any modification, alteration, or change by or on behalf of customer (except and unless modified, changed or altered by JS or under direct supervision of JS),
- (vi) the defect or malfunction results from misuse or accident,
- (vii) the serial number on the product has been tampered with or removed, or
- (viii) the product has been opened or tampered with in any way.

This warranty is exclusive and JS will not assume and hereby expressly disclaims any further warranties, whether express or implied, including, without limitation, any warranty as to merchantability, fitness for a particular purpose, non-infringement or any warranties arising from the course of performance, dealing, or usage of trade. JS specifically makes no warranties as to the suitability of its products for any particular application. JS makes no warranties that

- its products will meet your requirements or will work in combination with any hardware or applications software products provided by third parties,
- the operation of its products will be uninterrupted or error free, or
- all defects in the product will be corrected.

JS shall not be responsible for software, firmware, information, or memory data contained in, stored on, or integrated with any products returned to JS for repair, whether under warranty or not.

### **Remedy**

In the event a defect in materials or workmanship is discovered and reported to JS within the specified warranty period, JS will, at its option, repair the defect or replace the defective part or product. Replacement products may be new or reconditioned. JS warrants any replaced or repaired product for a period of ninety (90) days from the date of return shipment, or through the end of the original warranty period, whichever is longer.

### **Limitation of Liability**

To the fullest extent allowed by law, the obligation of JS shall be limited to the repair or replacement of the product. JS shall in no event be liable for special, incidental, or consequential, indirect, special or punitive damages of any kind, or for loss of revenue or profits, loss of business, loss of information or data, or other financial loss arising out of or in connection with the sale, installation, maintenance, use, performance, failure, or interruption of any product. Any



responsibility and/or liability of JS shall, in connection with a warranted product, be limited in the maximum amount to the original purchase price.

### **Warranty Repairs**

To obtain warranty repair or service on the Allegro 2, submit a repair order on our website at <http://www.junipersys.com/Juniper-Systems/support/Repairs> or contact an authorized repair center within the applicable warranty period.

Products returned for repair or service without proper authorization may acquire an additional handling fee and/or delay in the repair. The customer is responsible to prepay all shipping costs when sending equipment to a repair center. The repair center will return the repaired equipment by the same method it was received with costs of shipping prepaid.

### **Governing Law**

This warranty is governed by the laws of Utah, U.S.A. and excludes the United Nations Convention on Contracts for the International Sale of Goods. The courts of Utah shall have exclusive personal jurisdiction in case of any disputes arising out of or in connection with this warranty.

### **Services and Materials Provided Under Warranty**

- Analysis of problem by service technician
- Labor and materials required to fix defective parts
- Functional analysis performed after repair
- Repair turnaround within 10 working days of receipt unless special circumstances exist
- Shipping costs to return device to customer

### **Extended Warranties**

The Allegro 2 can be warranted up to 5 years (including the standard warranty period) through the purchase of an extended warranty.

Extended warranties apply only to the Allegro 2, not battery packs, media containing the Allegro 2 programs, desktop computer programs, user documentation, and accessories.

Parts that are excessively worn are not covered under all warranty plans. These may include, but are not limited to, the keyboard elastomer and switch matrix, hand straps, touchscreens, and connector modules.

### **Warranty Information**

Warranty information for the Allegro 2 Rugged Handheld is located on our website at <http://www.junipersys.com/Juniper-Systems/support/Warranty>. You can evaluate and order warranty extensions, check warranty status, and view warranty terms and conditions.

## **Repairing the Allegro 2**



**CAUTION:** Do not attempt to repair the Allegro 2 yourself. This action voids the warranty.

Information about repairs, upgrades, and evaluations is located on our website at <http://www.junipersys.com/Juniper-Systems/support/Repairs>. You can locate a repair center, submit a repair order, check repair status, view terms and conditions, get shipping instructions, and view lead times.

Before returning a unit, please get permission by submitting a repair order from our website and waiting for confirmation or by contacting a repair center directly. Be prepared to provide the following information:

- Product serial number (inside the battery compartment; also found in System Information screen as described on the following page)
- Your name
- Name and shipping address of company/university/agency
- Best contact method (phone, fax, email, cell/mobile)
- Clear, highly-detailed description of the repair or upgrade
- Credit card/ purchase order number and billing address (for a repair or upgrade that is not covered by the standard warranty or an extended warranty policy)

## System Information for your Allegro 2

When you contact a repair center, you need some unique system ID information for your Allegro 2 (serial number, model number, etc.). Select the System Info icon from the favorites bar on the Home screen or tap *Start > Settings > System > System Information* to view the *System Information* menu. Select *System ID*.



Specifications on the processor, memory, display, camera (Geo models), GPS (Geo models), *Bluetooth*, Wi-Fi, and cell modem (optional accessory) are also located on the *System Information* screen.

You can also create a system information file to send to the repair center by pressing the *Menu* soft key and selecting *Create Info File*. The file is located at: `\My Documents\JSInfo.txt`.



# Warnings and Regulatory Information

## Product Warnings

Follow the warnings listed below to use the Allegro 2 and accessories safely.



### Battery Warnings

**WARNING!** This device comes with a lithium ion rechargeable battery pack. To reduce the risk of fire or burns, do not disassemble, crush, puncture, short external contacts, or expose the battery pack to fire.

Do not disassemble or open, crush, bend or deform, puncture or shred.

Do not modify or remanufacture, attempt to insert foreign objects into the battery, immerse or expose to water or other liquids, expose to fire, explosion or other hazard.

Only use the battery for the system for which it is specified.

Only use the battery with a charging system that has been qualified with the system per this standard. Use of an unqualified battery or charger may present a risk of fire, explosion, leakage, or other hazard.

Do not short circuit a battery or allow metallic conductive objects to contact battery terminals.

Replace the battery only with another battery that has been qualified with the system.

Use of an unqualified battery may present a risk of fire, explosion, leakage or other hazard.

Promptly dispose of used batteries in accordance with local regulations.

Battery usage by children should be supervised.

Avoid dropping the battery. If the battery is dropped, especially on a hard surface, and the user suspects damage, take it to a service center for inspection.

Improper battery use may result in a fire, explosion or other hazard.



## Wall Charger Warnings

**WARNING!** To reduce the risk of personal injury, electrical shock, fire or damage to the equipment:

Plug the wall charger into an electrical outlet that is easily accessible at all times.

Do not place anything on the wall charger cord or any of the other cables. Arrange them so that no one may accidentally step on or trip over them.

Do not pull on a cord or cable. When unplugging the wall charger from the electrical outlet, pull on the plug, not the cord.

Use only wall chargers intended for the Allegro 2. Using any other external power source can damage your product and void your warranty.

## Certifications and Standards

### FCC - United States

In compliance with the FCC rules 47 CFR 15.19(a)(3), the statements that follow must appear on the device or in the user documentation.

This device complies with Part 15 of the FCC Rules. Operation is subject to the following two conditions:

1. The device may not cause harmful interference.
2. This device must accept any interference received, including interference that may cause undesired operation.

In compliance with the FCC rules, 47 CFR 15.105(b), the user must be notified that this equipment has been tested and found to comply with the limits for a Class B digital device, pursuant to part 15 of the FCC Rules. These limits are designed to provide reasonable protection against harmful interference in a residential installation. This equipment generates, uses and can radiate radio frequency energy and, if not installed and used in accordance with the instructions, may cause harmful interference to radio communications. However, there is no guarantee that interference will not occur in a particular installation. If this

equipment does cause harmful interference to radio or television reception, which can be determined by turning the equipment off and on, the user is encouraged to try to correct the interference by one or more of the following measures:

- Reorient or relocate the receiving antenna.
- Increase the separation between the equipment and receiver.
- Connect the equipment into an outlet on a circuit different from that to which the receiver is connected.
- Consult the dealer or an experienced radio/TV technician for help.

In compliance with the FCC rules, 47 CFR 15.21, the user must be notified that changes or modifications to the Rugged Handheld that are not expressly approved by the manufacturer could void the user's authority to operate the equipment.

Only approved accessories may be used with this equipment. In general, all cables must be high quality, shielded, correctly terminated, and normally restricted to two meters in length. Wall chargers approved for this product employ special provisions to avoid radio interference and should not be altered or substituted.

This device must not be co-located or operating in conjunction with any other antenna or transmitter.

This cell modem is compliant with FCC regulations when operated within the temperature range of -30°C to +50°C. Do not operate the cell modem outside of this temperature range.

### **Industry Canada**

In compliance with Industry Canada rules, the following statement must appear on the device or in the user documentation:

This Class B digital apparatus complies with Canadian ICES-003.

## Radio Frequency Safety

This device has been evaluated for use in close proximity to the body. Use only accessories approved by Juniper Systems. The use of third party accessories may not comply with FCC and international RF exposure requirements. To comply with FCC and other national RF exposure requirements do not co-locate this device with other transmitters.

This device operates in compliance with the FCC radio frequency exposure limits for an uncontrolled environment. Users must follow instructions provided in the user documentation to satisfy compliance with FCC radio frequency exposure requirements.

There cannot be any alteration to the authorized antenna system.

## CE Marking (European Union)



Products bearing the CE marking comply with the EU Directive 2014/53/EU.

CE compliance of this device is valid only if powered with/by a CE-marked wall charger provided by the manufacturer. Cables connecting to the USB host port must use a ferrite core/bead on the cable. The ferrite core must be placed on the cable near the end that connects to the Allegro 2.

## Declaration of Conformity

The Declaration of Conformity for CE Marking is available at: <http://www.junipersys.com/doc>.







# D Specifications

## Allegro 2 Rugged Handheld Specifications

FEATURE	SPECIFICATION
Operating System	<ul style="list-style-type: none"> <li>■ Microsoft® Windows Embedded Handheld 6.5.3 (completely compatible with Microsoft® Windows Mobile® 6.5.3)</li> <li>■ English, French, German, Spanish, Brazilian Portuguese</li> </ul>
Processor	<ul style="list-style-type: none"> <li>■ 1GHz ARM Cortex A8 i.MX53</li> </ul>
Memory	<ul style="list-style-type: none"> <li>■ 512 MB DDR2 RAM</li> </ul>
Primary Data Storage	<ul style="list-style-type: none"> <li>■ 8 GB Flash storage</li> </ul>
Micro SD/SDHC Card Slot	<ul style="list-style-type: none"> <li>■ SD/SDHC slot, user accessible up to 32GB of storage</li> </ul>
Physical Features	<ul style="list-style-type: none"> <li>■ Dimensions, standard: 5.4" wide x 10.2" long x 1.6" thick (138 mm x 255 mm x 40 mm)</li> <li>■ Weight:               <ul style="list-style-type: none"> <li>Standard - 2.01 lb. (910 g)</li> <li>Geo - 2.09 lb. (946 g)</li> <li>Geo Barcode- 2.22 lb. (1006 g)</li> <li>Geo Cell - 2.15 lb. (972 g)</li> <li>Geo Cell Barcode- 2.28 lb. (1034 g)</li> </ul> </li> <li>■ Durable hardened plastic in a shear-proof, shock-resistant design</li> <li>■ Shock-resistant bumpers</li> <li>■ Strong chemical resistance</li> <li>■ Easy to grip ergonomic form factor</li> <li>■ Comfortable, wide hand strap</li> </ul>
Display	<ul style="list-style-type: none"> <li>■ Active viewing area: 4.2" (107 mm) color WVGA LCD TFT</li> <li>■ 640 x 480 pixel resolution</li> <li>■ LCD backlight</li> <li>■ Outdoor viewable</li> <li>■ Landscape orientation</li> </ul>

FEATURE	SPECIFICATION
Touchscreen	<ul style="list-style-type: none"> <li>■ Capacitive touch interface</li> <li>■ Chemically-strengthened glass</li> <li>■ Touchscreen disable function</li> <li>■ Touchscreen profile options</li> </ul>
Keyboard	<ul style="list-style-type: none"> <li>■ Alphanumeric QWERTY keyboard</li> <li>■ Modifier keys</li> <li>■ Multiple programmable keys and LEDs</li> <li>■ Backlight</li> <li>■ On-screen keyboard for atypical characters</li> </ul>
Batteries	<ul style="list-style-type: none"> <li>■ Rechargeable Li-Ion battery pack, 3.6VDC 12000mAh, 43.2Whr</li> <li>■ Run time of up to 20 hours</li> <li>■ Charging time 4 to 5 hours</li> <li>■ Quick charge</li> <li>■ Built-in battery intelligence</li> <li>■ User-replaceable</li> </ul>
Connector I/O Module	<ul style="list-style-type: none"> <li>■ RS-232C 9-pin D-sub connector, +5V @ 500 mA available on ring in pin 9 via software configuration</li> <li>■ USB Host (Full A)</li> <li>■ USB Client (Micro B)</li> <li>■ 12-24 VDC jack for power input and battery charging, +12VDC 1.67A</li> <li>■ 3.5mm audio jack, supports speaker/microphone or stereo output (pin detect).</li> </ul>
Wireless Connectivity	<ul style="list-style-type: none"> <li>■ <i>Bluetooth</i><sup>®</sup> wireless technology 2.1 +EDR Class 1, range greater than 100 feet (30 m)</li> <li>■ Wi-Fi 802.11b/g/n with extended range. U.S. and international</li> </ul>
Audio	<ul style="list-style-type: none"> <li>■ Speaker, loud and clear</li> <li>■ Microphone, low noise</li> <li>■ 3.5mm audio jack, supports stereo headset and microphone at the same time (speaker disable)</li> </ul>

FEATURE	SPECIFICATION
LED Activity Indicators	<ul style="list-style-type: none"> <li>■ Red: power applied/charging status</li> <li>■ Green: notification, application programmable</li> <li>■ Blue: application programmable</li> </ul>
Temperature Specifications	<ul style="list-style-type: none"> <li>■ Operating Temperature: <math>-22^{\circ}</math> to <math>140^{\circ}</math> F (<math>-30^{\circ}</math> to <math>60^{\circ}</math> C). <i>Note: Bluetooth® wireless technology is rated to <math>-4^{\circ}</math> to <math>122^{\circ}</math> F (<math>-20^{\circ}</math> to <math>50^{\circ}</math> C).</i></li> <li>■ Storage Temperature: <math>-22^{\circ}</math> to <math>158^{\circ}</math> F (<math>-30^{\circ}</math> to <math>70^{\circ}</math> C)</li> <li>■ Battery Charging Temperature: <math>32^{\circ}</math> to <math>122^{\circ}</math> F (<math>0^{\circ}</math> to <math>50^{\circ}</math> C)</li> </ul>
Shock Resistance	<ul style="list-style-type: none"> <li>■ Withstands multiple 4 foot drops to concrete</li> </ul>
Environmental Ratings and Standards	<ul style="list-style-type: none"> <li>■ IP68 rating, waterproof and dustproof</li> <li>■ MIL-STD810G test procedures: Method 500.5 Low Pressure (Altitude); Method 501.5 High Temperature; Method 502.5 Low Temperature; Method 503.5 Temperature Shock; Method 506.5 Rain; Method 507.5 Humidity; Method 510.5 Sand and Dust; Method 512.5 Immersion; Method 514.6 Vibration; Method 516.6 Shock</li> </ul>
Warranties	<ul style="list-style-type: none"> <li>■ 24 months for Allegro 2</li> <li>■ 90 days for accessories</li> <li>■ Extended service and maintenance plans</li> </ul>

FEATURE	SPECIFICATION
Software Included	<ul style="list-style-type: none"> <li>■ ActiveSync</li> <li>■ Adobe Reader LE</li> <li>■ Alarms</li> <li>■ Barcode Connector</li> <li>■ Calculator</li> <li>■ Calendar</li> <li>■ Contacts</li> <li>■ E-Mail</li> <li>■ File Explorer</li> <li>■ Getting Started</li> <li>■ GNSS Stream</li> <li>■ Help</li> <li>■ Internet Explorer</li> <li>■ Internet Sharing</li> <li>■ JSNav</li> <li>■ Juniper Home screen, customizable with selectable dashboard gadgets and program shortcuts</li> <li>■ Juniper On-Screen Keyboards, Mega Keys and Mega Keys Night</li> <li>■ Notes</li> <li>■ Pictures &amp; Videos</li> <li>■ Remote Desktop Mobile</li> <li>■ Search</li> <li>■ Settings</li> <li>■ Task Manager</li> <li>■ Tasks</li> <li>■ Windows Live</li> <li>■ Windows Media</li> <li>■ Windows Office Mobile</li> </ul> <p><i>Note: Software on individual units may vary from this list.</i></p>

FEATURE	SPECIFICATION
Configurations	<ul style="list-style-type: none"> <li>■ Standard with Wi-Fi, <i>Bluetooth</i>, 512MB RAM, 8GB Storage</li> <li>■ Geo with Standard features plus Camera and GPS</li> <li>■ Geo Barcode with Geo features plus Barcode Scanner</li> <li>■ Geo Cell with Geo features plus Cell</li> <li>■ Geo Barcode Cell with Geo Barcode features plus Cell</li> </ul> <p><i>US/North America and CE/EU Models</i></p>
Camera (Geo models)	<ul style="list-style-type: none"> <li>■ 5MP resolution</li> <li>■ Autofocus</li> <li>■ Video capture</li> <li>■ JPEG image format</li> <li>■ Juniper Geotagging; embed and/or emboss photo with date, time and GPS position</li> <li>■ Flash and flashlight</li> </ul>
3G Data Modem (Geo model option)	<ul style="list-style-type: none"> <li>■ Integrated Cinterion PH8P module (Pentaband Worldwide), 800/850/900/1800/1900/2100 MHz data speeds, UMTS/HSPA+3GPP</li> <li>■ Does not support voice calls or SMS</li> <li>■ Communicates on GSM-based networks</li> <li>■ Supports mini-SIM card only</li> </ul>

FEATURE	SPECIFICATION
GPS/GNSS (Geo models)	<ul style="list-style-type: none"> <li>■ High-sensitivity GPS/GLONASS/SBAS receiver</li> <li>■ 2 to 5 meter typical accuracy</li> <li>■ Post-processing capability for enhanced accuracy beyond 2 to 5 meters, proprietary protocol</li> <li>■ Integrated real-time SBAS capability, support for WAAS, MSAS, EGNOS</li> <li>■ File format NMEA-0183 v2.3, default strings: RMC, GSA, GNS, GBS, VTG, GSV, ZDA, DTM, GGA, GLL</li> <li>■ 72 GNSS tracking channels</li> <li>■ GPS signal quality indicator on Juniper Home screen</li> <li>■ JNav application</li> <li>■ GNSS Stream Application</li> </ul>
Certifications and Standards	<ul style="list-style-type: none"> <li>■ FCC Class B</li> <li>■ CE Marking (applicable EMC, R&amp;TTE, and LVD directives)</li> <li>■ Industry Canada</li> <li>■ EN60950 Safety</li> <li>■ <i>Bluetooth</i> SIG qualification</li> <li>■ USB client</li> <li>■ IP68 waterproof and dustproof</li> <li>■ Designed to MIL-STD 810G</li> </ul>
Barcode Scanner (Geo Barcode model option)	<ul style="list-style-type: none"> <li>■ Imager and Decoder: Motorola/Symbol SE4500 imager and PL3307C 400MHz decoder</li> <li>■ Sensor Resolution: 752 X 480</li> <li>■ Field of View: Horizontal 40°, vertical 25°</li> <li>■ Reading Angles: Skew &amp; pitch <math>\pm 60^\circ</math>, roll 360°</li> <li>■ Read Range: 1" to 24" depending on code type, size, and density</li> <li>■ Aiming Crosshair Pattern: Visible with low light illumination</li> </ul>



FEATURE	SPECIFICATION
Barcode Scanner (Geo Barcode model option) <i>continued</i>	<ul style="list-style-type: none"> <li>■ Symbologies: All common 1D, 2D (PDF417, MicroPDF417, Composite, RSS, TLC-39, Data matrix, QR code, Micro QR code, Aztec, MaxiCode, Postal codes, etc.)</li> <li>■ Trigger Buttons: Programmable</li> <li>■ Barcode Connector™ Utility: Wedge and configuration</li> <li>■ Certification: Class 1 Laser and LED Product</li> <li>■ Power: 1.49W active, 0.54W standby, 8mW sleep; by default device returns to sleep after 1 second of inactivity</li> </ul>
Standard Accessories	<ul style="list-style-type: none"> <li>■ Li-Ion battery</li> <li>■ Hand strap (pre-installed)</li> <li>■ USB micro client sync cable</li> <li>■ AC wall charger with international plug kit <ul style="list-style-type: none"> <li>- Input: 100-240VAC, 50/60Hz, 0.5A</li> <li>- Output: 12VDC, 1.67A</li> </ul> </li> <li>■ Capacitive stylus and tether</li> <li>■ Screwdriver</li> <li>■ Quick Start Guide</li> <li>■ Owner's Manual available on our website</li> <li>■ Two year warranty</li> </ul>
Optional Accessories	<ul style="list-style-type: none"> <li>■ Shoulder strap</li> <li>■ Serial cable</li> <li>■ Vehicle charging adaptor</li> <li>■ Holster case</li> <li>■ Flip cover fitted case</li> <li>■ 8GB micro SDHC memory card</li> <li>■ Premium screen protectors</li> </ul> <p style="text-align: center;"><i>See your sales associate for more details on optional accessories.</i></p>

*Note: Specifications are subject to change without notice.*



# Index

# Index

## Symbols

- 3G Data Modem 80
  - Connection Problems 83
  - Data Account, Set up With Wireless Provider 80
  - Gadget Color Indicators 35
  - Maintenance of Your Modem 83
  - RF Interference Issues 83
  - Set up the Cell Modem 82
  - SIM Card Installation 80

## A

- Accelerometer 42
- ActiveSync
  - Creating a Partnership 44
- Anatomy of the Rugged Handheld 2
- Audio Features 30
  - Audio Jack 30
  - Microphone 30
  - Speaker 30

## B

- Backlight 21
- Barcode Connector Utility 88
- Barcode Scanner 86
  - Barcode Connector Utility 88
  - Barcode Setup 89
  - Sample Barcodes 98
  - Troubleshooting 96
- Battery Pack
  - Battery Life 24
  - Specifications 119
  - Storage 102
  - Warnings 112
- Bluetooth Wireless Communication
  - Microsoft Bluetooth Control Panel 47
  - Serial Device (COM) Control Panel 49

## C

### Camera

- Embed User Note 75
- Emboss Picture Options 73
- Flash Option 73
- Geotagging Pictures 73
- Photo and Video Library 77
- Specifications 122
- Videos 73

### Care and Maintenance

- Cleaning 103
- Storage 102

Cautions 24, 28, 40, 41, 81, 103, 104, 109

Certifications and Standards 113

Cleaning 103

### Communicating With a Computer

- ActiveSync 44
- Windows Mobile Device Center 44

Compass and Accelerometer Calibration 42, 63, 73

- Sensors Control Panel 43

Computer, Communicating With 43

Connector Module 29

- Cleaning 103

## D

Dashboard 33

- Dashboard Gadgets 34

Declaration of Conformity 115

### Display

- Backlight 21
- Subdued Lighting (Tactical) Mode 41
- Disabling 19

## E

Emboss Picture Options 74

Equipment Warnings 113

## F

Favorites Bar 35

- Application Shortcuts 35

Flashlight 34  
Flash Option 73

## G

Gadgets 34  
Geo Model 56, 72  
Geotagging 73  
    Emboss Picture Options 74  
Getting Started Screen 44  
GNSS Modes 59  
GNSS Static Hold 58  
GPS Compass 63  
GPS/GNSS 56, 123  
    Accuracy 60  
    Bluetooth COM Port Set Up 49  
    Camera  
        Geotagging Pictures 73  
    Compass 63  
    Gadgets 34  
    GPS Intermediate Driver 57, 59  
    Settings 57  
GSM Modem 80

## H

Hardware Features 12  
Hold to Zoom. *See* Zoom in on Display  
Home Screen 7  
    Dashboard 33  
    Dashboard Gadgets 34  
    Status Icons 33  
    Tile Bar 36  
    Title Bar 33  
    Touchable Tiles 36

## J

JSNav Application 63

## K

- Keyboard, On-screen 37
- Keypad 12
  - Function Buttons 12
  - Navigation Buttons 12
  - Press and Hold Functions 12
  - Press and Release Functions 12
  - Reassignable Buttons 12

## L

- Language Installs 7
- Limitation of Liability 107

## M

- Mega Keys 38
- Microphone 29, 30, 119
- Microsoft® Windows® Embedded Handheld 6.5.3 118

## N

- Navigating Around the Rugged Handheld
  - Touch Gestures 12

## O

- Online Help 44
- On-Screen Keyboard 37
- Operating System 118
  - Updates 7
- Orange Power Key Menu 17

## P

- Power Management
  - Battery Pack 24
  - Charging Battery Packs 26
- Power Off 40
- Product Warnings 112
- Program Buttons. *See* Programmable Keys
- Programmable Keys 17

## R

- Recycling the Rugged Handheld and Batteries 104
- Repairing 109
  - System Information 110
- Reset 40
- Restore 41
- Resume 39
- RS-232C Port 29, 119

## S

- Scan Button Set-up 86
- Screen Protector 4
- SD Cards 28
- SDK 44
- Sensors Control Panel 43
- SIM Card 3, 4
- Soft Keys (Touchable Tiles) 36
- Software Developers 44
- Speaker 30, 119
- Specifications 118–125
- Start Menu 7
- Storing the Rugged Handheld and Battery Pack 102
- Subdued Lighting (Tactical) Mode 41
- Suspend 39
- Synchronization Software 43
- System Information 80, 109, 110

## T

- Tactical Lighting Mode 41
- Temperature Specifications 120
- Tile Bar 36
- Title Bar 33
- Touchable Tiles (Soft Keys) 36
- Touchscreen
  - Disabling and Enabling 19
  - Display Backlight 21
  - Protecting the Touchscreen 103
  - Settings 19
  - Specifications 119
  - Touchscreen Modes 19

## U

- Updates, Operating System and Documentation 7
- USB Client 29, 123
- USB Host 29

## W

- Warnings 112, 113
- Warranty 106–109
  - Exclusions 106
  - Extended Warranties 108
  - Limitation of Liability 107
  - Remedy 107
  - Repairs 108
  - Services 108
  - Warranty Exclusions 106
  - Warranty Repairs 108
- Wi-Fi Wireless Communication
  - Connecting to a Wi-Fi Network 52
  - Managing Connections 53
  - Wi-Fi Dialog Box 53
  - Wi-Fi Set up Screens 53
- Windows Mobile Device Center 44
- Windows Start Menu 7

## Z

- Zoom in on Display 20